

Catalyst Alarm

Component Manual

This manual is applicable to the following models:

- ECA-5000
- ECA-5000-IND

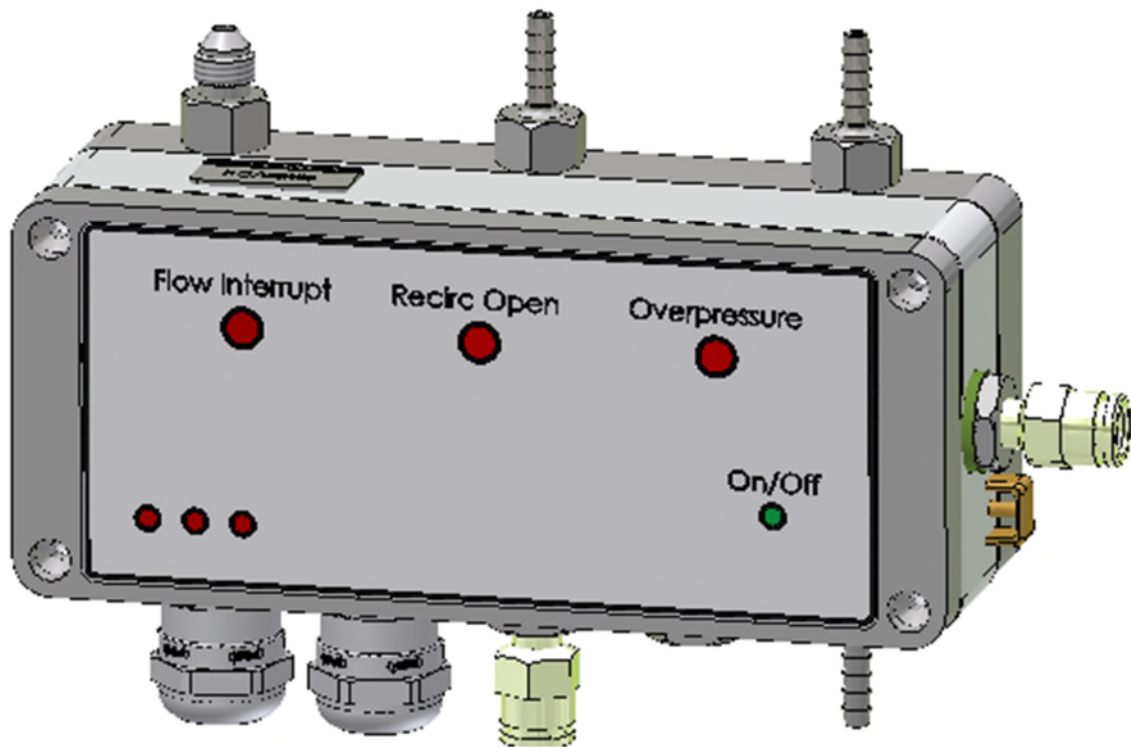

Revision: 2
Revised March 2020



CORPORATE HEADQUARTERS

2030 Falling Waters Rd, Suite 350, Knoxville, TN 37922 · USA · Tel: (865) 686-5670

DISTRIBUTION AND PURCHASING

642 Barbrow Ln, Knoxville, TN 37932 · USA · Tel: (865) 684-4416

TECHNOLOGY CENTER AND MANUFACTURING

1862 Ives Ave, Kent, WA 98032 · USA · Tel (253) 854-2660 · Fax (253) 854-1666

E-mail: info@mvpind.com

For a list of international distributors, visit our website at :

www.mvpind.com/mvp-international

Use of this product confirms that Magnum Venus Products, Inc.'s standard terms and conditions of sale apply.



Table of Contents

Section	Page
• Table of Contents	3
• Safety & Warning Information	4
• Introduction	15
• Installing Unit	17
• Setting Up and Configuring	24
• Operating Catalyst Alarm	25
• Performing Maintenance	26
• Troubleshooting	27
• System Components	28
• Warranty	34

Safety & Warning Information

Warnings

Due to the vast number of chemicals that could be used and their varying chemical reactions, the buyer and user of this equipment should determine all factors relating to the fluids used, including any of the potential hazards involved. Particular inquiry and investigation should be made into potential dangers relating to toxic fumes, fires, explosions, reaction times, and exposure of human beings to the individual components or their resultant mixtures. MVP assumes no responsibility for loss, damage, expense or claims for bodily injury or property damage, direct or consequential, arising from the use of such chemical components.

The end user is responsible for ensuring that the end product or system complies with all the relevant laws in the country where it is to be used and that all documentation is adhered to.

Recommended Occupational Safety & Health Act (OSHA) Documentation:

- 1910.94 Pertaining to ventilation
- 1910.106 Pertaining to flammable liquids
- 1910.107 Pertaining to spray finishing operations, particularly paragraph (m), Organic Peroxides and Dual Component Coatings

For Additional information, contact the Occupational Safety and Health Administration (OSHA) at <https://www.osha.gov/about.html>.

Recommended National Fire Protection Association (NFPA) Documentation:

- NFPA No.33 Chapter 14 Organic Peroxides and Dual Component Materials
- NFPA No. 63 Dust Explosion Prevention
- NFPA No. 70 National Electrical Code
- NFPA No. 77 Static Electricity
- NFPA No. 91 Blower and Exhaust System
- NFPA No. 654 Plastics Industry Dust Hazards

Fire Extinguisher – code ABC, rating number 4a60bc using Extinguishing Media –Foam, Carbon Dioxide, Dry Chemical, Water Fog, is recommended for this product and applications.

The following general warnings and guidelines are for the setup, use, grounding, maintenance, and repair of equipment. Additional product-specific warnings may be found throughout this manual as applicable. Please contact your nearest MVP Technical Service Representative if additional information is needed.

Safety Precautions

- Avoid skin contact and inhalation of all chemicals.
- Review Material Safety Data Sheet (MSDS) to promote the safe handling of chemicals in use.
- Restrict the use of all chemicals to designated areas with good ventilation.
- Chemicals are flammable and reactive.
- Noxious fumes released when combusted.
- Operate equipment in a ventilated environment only.
- Uncured liquid resins are highly flammable unless specifically labeled otherwise.
- Cured laminate, accumulations of overspray, and laminate sandings are highly combustible.
- Do not operate or move electrical equipment when flammable fumes are present.
- Ground all equipment.
- If a spark is seen or felt, immediately halt operation. Do not operate the equipment until the issue has been identified and repaired.
- Contaminated catalyst may cause fire or explosion.
- Containers may explode if exposed to fire / heat.
- Use and store chemicals away from heat, flames, and sparks.
- Do not smoke in work areas or near stored chemicals.
- Do not mix Methyl Ethyl Ketone Peroxide (MEKP) with materials other than polyethylene.
- Do not dilute MEKP.
- Keep food and drink away from work area.



Physical Hazards

- Never look directly into the spray gun fluid tip. Serious injury or death can result.
- Never aim the spray gun at or near another person. Serious injury or death can result.
- Chemical compounds can be severely irritating to the eyes and skin.
- Inhalation, ingestion, or injection may damage internal organs and lead to pulmonary disorders, cancers, lymphomas, and other diseases or health conditions.
- Other potential health effects include: irritation of the eyes and upper respiratory tract, headache, light-headedness, dizziness, confusion, drowsiness, nausea, vomiting, and occasionally abdominal pain.
- Eye contact: Immediately flush with water for at least 15 minutes and seek immediate medical attention.
- Skin Contact: Immediately wash with soap and water and seek immediate medical attention.
- Inhalation: Move the person to fresh air and seek immediate medical attention.
- Do not remove shields, covers, or safety features on equipment that is in use.
- Never place fingers, hands, or any body part near or directly in front of the spray gun fluid tip. The force of the liquid as it exits the spray tip can shoot liquid through the skin.
- Keep hands and body parts away from any moving equipment or components.
- Do not stand under plunger
- An improperly loaded drum may lead to an imbalance, causing a unit to tip over

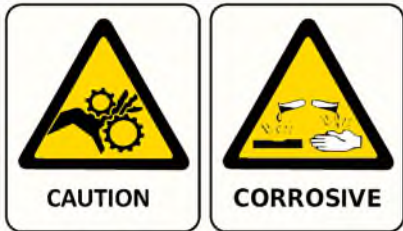

Personal Protective Equipment (PPE)

- MVP recommends the use of personal safety equipment with all products in our catalog.
- Wear safety goggles, hearing protection, a respirator, and chemical resistant gloves.
- Wear long sleeve shirts or jackets and pants to minimize skin exposure.
- PPE should be worn by operators and service technicians to reduce the risk of injury.



For Additional information, contact the Occupational Safety and Health Administration (OSHA). <https://www.osha.gov/about.html>

Symbol Definitions



Indicates the risk of contact with chemicals that are hazardous, which may lead to injury or death.



Indicates the risk of contact with voltage / amperage that may lead to serious injury or death.



Indicates that the materials being used are susceptible to combustion.



Indicates the risk of contact with moving components that may lead to serious injury or death.



Indicates that the system or component should be grounded before proceeding with use or repair.



Indicates the use of lit cigarettes or cigars is prohibited, because the materials being used are susceptible to combustion.



Indicates that the materials and/or the process being performed can lead to ignition and explosion.



A recommendation for the use of Personal Protective Equipment (PPE) before using or repairing the product.

Polymer Matrix Materials: Advanced Composites

Potential health hazards associated with the use of advanced composites can be controlled through the implementation of an effective industrial hygiene and safety program.

https://www.osha.gov/dts/osta/otm/otm_iii/otm_iii_1.html#t_iii:1_1

Resins		
Composite Component	Organ System Target (Possible Target)	Known (Possible) Health Effect
Epoxy resins	Skin, lungs, eyes	Contact and allergic dermatitis, conjunctivitis
Polyurethane resins	Lungs, skin, eyes	Respiratory sensitization, contact dermatitis, conjunctivitis
Phenol formaldehyde	Skin, lungs, eyes	As above (potential carcinogen)
Bismaleimides (BMI)	Skin, lungs, eyes	As above (potential carcinogen)
Polyamides	Skin, lungs, eyes	As above (potential carcinogen)
Reinforcing materials		
Composite Component	Organ System Target (Possible Target)	Known (Possible) Health Effect
Aramid fibers	Skin (lungs)	Skin and respiratory irritation, contact dermatitis (chronic interstitial lung disease)
Carbon/graphite fibers	Skin (lungs)	As noted for aramid fibers
Glass fibers (continuous filament)	Skin (lungs)	As noted for aramid fibers
Hardeners and curing agents		
Composite Component	Organ System Target (Possible Target)	Known (Possible) Health Effect
Diaminodiphenylsulfone	N/A	No known effects with workplace exposure
Methylenedianiline	Liver, skin	Hepatotoxicity, suspect human carcinogen
Other aromatic amines		
Composite Component	Organ System Target (Possible Target)	Known (Possible) Health Effect
Meta-phenylenediamine (MPDA)	Liver, skin (kidney, bladder)	Hepatitis, contact dermatitis (kidney and bladder cancer)
Aliphatic and cyclo-aliphatic amines	Eyes, skin	Severe irritation, contact dermatitis
Polyaminoamide	Eyes, skin	Irritation (sensitization)
Anhydride	Eyes, lungs, skin	Severe eye and skin irritation, respiratory sensitization, contact dermatitis

Catalyst - Methyl Ethyl Ketone Peroxide (MEKP)

MEKP is among the more hazardous materials found in commercial channels. The safe handling of the “unstable (reactive)” chemicals presents a definite challenge to the plastics industry. The highly reactive property which makes MEKP valuable to the plastics industry in producing the curing reaction of polyester resins also produces the hazards which require great care and caution in its storage, transportation, handling, processing and disposal. MEKP is a single chemical. Various polymeric forms may exist which are more or less hazardous with respect to each other. These differences may arise not only from different molecular structures (all are, nevertheless, called “MEKP”) and from possible trace impurities left from the manufacture of the chemicals, but may also arise by contamination of MEKP with other materials in its storage or use. Even a small amount of contamination with acetone, for instance, may produce an extremely shock-sensitive and explosive compound.



WARNING

Contamination with promoters, materials containing promoters (such as laminate sandings), or with any readily oxidizing material (such as brass or iron) will cause exothermic redox reactions which can be explosive in nature. Heat applied to MEKP or heat buildup from contamination reactions can cause the material to reach its Self-Accelerating Decomposition Temperature (SADT).

Researchers have reported measuring pressure rates-of-rise well over 100,000 psi per second when certain MEKP's reach their SADT. For comparison, the highest-pressure rate-of-rise listed in NFPA Bulletin NO.68, “Explosion Venting”, is 12,000 psi per second for an explosion of 12% acetylene and air. The maximum value listed for a hydrogen explosion is 10,000 psi per second. Some forms of MEKP, if allowed to reach their SADT, will burst even an open topped container. This suggests that it is not possible to design a relief valve to vent this order of magnitude of pressure rate-of-rise. The user should be aware that any closed container, be it a pressure vessel, surge chamber, or pressure accumulator, could explode under certain conditions. There is no engineering substitute for care by the user in handling organic peroxide catalysts. If, at any time, the pressure relieve valve on top of the catalyst tank should vent, the area should be evacuated at once and the fire department called. The venting could be the first indication of a heat, and therefore, pressure build-up that could eventually lead to an explosion. Moreover, if a catalyst tank is sufficiently full when the pressure relief valve vents, some catalyst may spray out, which could cause eye injury. For this reason, and many others, anyone whose job puts them in an area where this vented spray might go, should always wear full eye protection even when laminating operations are not taking place.

Safety in handling MEKP depends to a great extent on employee education, proper safety instructions, and safe use of the chemicals and equipment. Workers should be thoroughly informed of the hazards that may result from improper handling of MEKP, especially regarding contamination, heat, friction and impact. They should be thoroughly instructed regarding the proper action to be taken in the storage, use, and disposal of MEKP and other hazardous materials used in the laminating operation. In addition, users should make every effort to:

- Store MEKP in a cool, dry place in original containers away from direct sunlight and away from other chemicals.
- Keep MEKP away from heat, sparks, and open flames.
- Prevent contamination or MEKP with other materials, including polyester over spray and sandings, polymerization accelerators and promoters, brass, aluminum, and non-stainless steels.

- Never add MEKP to anything that is hot, since explosive decomposition may result.
- Avoid contact with skin, eyes, and clothing. Protective equipment should be worn at all times. During clean-up of spilled MEKP, personal safety equipment, gloves, and eye protection must be worn. Firefighting equipment should be at hand and ready.
- Avoid spillage, which can heat up to the point of self-ignition.
- Repair any leaks discovered in the catalyst system immediately, and clean-up the leaked catalyst at once in accordance with the catalyst manufacturer's instructions.
- Use only original equipment or equivalent parts from Magnum Venus Products in the catalyst system (i.e.: hoses, fitting, etc.) because a dangerous chemical reaction may result between substituted parts and MEKP.
- Catalyst accumulated from the purging of hoses or the measurement of fluid output deliveries should never be returned to the supply tank, such catalyst should be diluted with copious quantities of clean water and disposed of in accordance with the catalyst manufacturer's instructions.

The extent to which the user is successful in accomplishing these ends and any additional recommendations by the catalyst manufacturer determines largely the safety that will be present in his operation.

Clean-Up Solvents and Resin Diluents



WARNING

A hazardous situation may be present in your pressurized fluid system! Hydrocarbon solvents can cause an explosion when used with aluminum or galvanized components in a closed (pressurized) fluid system (pump, heaters, filters, valves, spray guns, tanks, etc.). An explosion could cause serious injury, death, and/or substantial property damage. Cleaning agents, coatings, paints, etc. may contain Halogenated Hydrocarbon solvents. Some Magnum Venus Products spray equipment includes aluminum or galvanized components and will be affected by Halogenated Hydrocarbon solvents.

There are three key elements to the Halogenated Hydrocarbon (HHC) solvent hazard.

- | | | |
|----|---|--|
| 1. | The presence of HHC solvents. | 1,1,1 – Trichloroethane and Methylene Chloride are the most common of these solvents. However, other HHC solvents are suspect if used; either as part of paint or adhesives formulation, or for clean-up flushing. |
| 2. | Aluminum or Galvanized Parts. | Most handling equipment contains these elements. In contact with these metals, HHC solvents could generate a corrosive reaction of a catalytic nature. |
| 3. | Equipment capable of withstanding pressure. | When HHC solvent contact aluminum or galvanized parts inside a closed container such as a pump, spray gun, or fluid handling system, the chemical reaction can, over time, result in a build-up of heat and pressure, which can reach explosive proportions. When all three elements are present, the result can be an extremely violent explosion. The reaction can be sustained with very little aluminum or galvanized metal; any amount of aluminum is too much. |
- The reaction is unpredictable. Prior use of an HHC solvent without incident (corrosion or explosion) does NOT mean that such use is safe. These solvents can be dangerous alone (as a

clean-up or flushing agent) or when used as a component or a coating material. There is no known inhibitor that is effective under all circumstances. Mixing HHC solvents with other materials or solvents such as MEKP, alcohol, or toluene may render the inhibitors ineffective.

- The use of reclaimed solvents is particularly hazardous. Reclaimers may not add any inhibitors. The possible presence of water in reclaimed solvents could also feed the reaction.
- Anodized or other oxide coatings cannot be relied upon to prevent the explosive reaction. Such coatings can be worn, cracked, scratched, or too thin to prevent contact. There is no known way to make oxide coatings or to employ aluminum alloys to safely prevent the chemical reaction under all circumstances.
- Several solvent suppliers have recently begun promoting HHC solvents for use in coating systems. The increasing use of HHC solvents is increasing the risk. Because of their exemption from many state implementation plans as Volatile Organic Compounds (VOCs), their low flammability hazard, and their not being classified as toxic or carcinogenic substances, HHC solvents are very desirable in many respects.



WARNING

Do not use Halogenated Hydrocarbon (HHC) solvents in pressurized fluid systems having aluminum or galvanized wetted parts. Magnum Venus Products is aware of NO stabilizers available to prevent HHC solvents from reaction under all conditions with aluminum components in closed fluid systems. HHC solvents are dangerous when used with aluminum components in a closed fluid system.

- Consult your material supplier to determine whether your solvent or coating contains Halogenated Hydrocarbon solvents.
- Magnum Venus Products recommends that you contact your solvent supplier regarding the best non-flammable clean-up solvent with the heat toxicity for your application.
- If, however, you find it necessary to use flammable solvents, they must be kept in approved, electrically grounded containers.
- Bulk solvent should be stored in a well-ventilated, separate building, 50 feet away from your main plant.
- You should only allow enough solvent for one day's use in your laminating area.
- NO SMOKING signs must be posted and observed in all areas of storage or where solvents and other flammable materials are used.
- Adequate ventilation (as covered in OSHA Section 1910.94 and NFPA No.91) is important wherever solvents are stored or used, to minimize, confine and exhaust the solvent vapors.
- Solvents should be handled in accordance with OSHA Section 1910.106 and 1910.107.

Catalyst Diluents

Magnum Venus Products spray-up and gel-coat systems currently produced are designed so that catalyst diluents are not required. Magnum Venus Products therefore recommends that diluents not be used to avoid possible contamination which could lead to an explosion due to the handling and mixing of MEKP and diluents. In addition, it eliminates any problems from the diluent being contaminated through rust particles in drums, poor quality control on the part of the diluents suppliers, or any other reason. If diluents are absolutely required, contact your catalyst supplier and follow his instructions explicitly. Preferably the supplier should premix the catalyst to prevent possible "on the job" contamination while mixing.

**WARNING**

If diluents are not used, remember that catalyst spillage and gun, hose, and packing leaks are potentially more hazardous since each drop contains a higher concentration of catalyst and will therefore react more quickly with overspray and the leak.

Cured Laminate, Overspray and Laminate Sandings Accumulation

- Remove all accumulations of overspray, Fiberglass Reinforced Plastic (FRP) sandings, etc. from the building as they occur. If this waste is allowed to build up, spillage of catalyst is more likely to start a fire; in addition, the fire would burn hotter and longer.
- Floor coverings, if used, should be non-combustible.
- Spilled or leaked catalyst may cause a fire if it comes in contact with an FRP product, oversprayed chop or resin, FRP sandings or any other material with MEKP.

To prevent spillage and leakage, you should:

- | | |
|--|---|
| 1. Maintain your Magnum Venus Products System. | Check the gun several times daily for catalyst and resin packing or valve leaks. REPAIR ALL LEAKS IMMEDIATELY. |
| 2. Never leave the gun hanging over or lying inside the mold. | A catalyst leak in this situation would certainly damage the part, possibly the mold, and may cause a fire. |
| 3. Inspect resin and catalyst hoses daily for wear or stress at the entry and exits of the boom sections and at the hose and fittings. | Replace if wear or weakness is evident or suspected. |
| 4. Arrange the hoses and fiberglass roving guides so that the fiberglass strands DO NOT rub against any of the hoses at any point. | If allowed to rub, the hose will be cut through, causing a hazardous leakage of material which could increase the danger of fire. Also, the material may spew onto personnel in the area. |

Toxicity of Chemicals

- Magnum Venus Products recommends that you consult OSHA Sections 1910.94, 1910.106, 1910.107 and NFPA No.33, Chapter 14, and NFPA No.91.
- Contact your chemical supplier(s) and determine the toxicity of the various chemicals used as well as the best methods to prevent injury, irritation and danger to personnel.
- Also determine the best methods of first aid treatment for each chemical used in your plant.

Equipment Safety

Magnum Venus Products suggest that personal safety equipment such as EYE GOGGLES, GLOVES, EAR PROTECTION, and RESPIRATORS be worn when servicing or operating this equipment. Ear protection should be worn when operating a fiberglass chopper to protect against hearing loss since noise levels can be as high as 116 dB (decibels). This equipment should only be operated or serviced by technically trained personnel!

**CAUTION**

Never place fingers, hands, or any body part near or directly in front of the spray gun fluid tip. The force of the liquid as it exits the spray tip can cause serious injury by shooting liquid through the skin. NEVER LOOK DIRECTLY INTO THE GUN SPRAY TIP OR POINT THE GUN AT OR NEAR ANOTHER PERSON OR AN ANIMAL.

**DANGER**

Contaminated catalyst may cause fire or explosion. Before working on the catalyst pump or catalyst accumulator, wash hands and tools thoroughly. Be sure work area is free from dirt, grease, or resin. Clean catalyst system components with clean water daily.

**DANGER**

Eye, skin, and respiration hazard. The catalyst MEKP may cause blindness, skin irritation, or breathing difficulty. Keep hands away from face. Keep food and drink away from work area.

Treatment of Chemical Injuries

**CAUTION**

Refer to your catalyst manufacturer's safety information regarding the safe handling and storage of catalyst. Wear appropriate safety equipment as recommended.

Great care should be used in handling the chemicals (resins, catalyst and solvents) used in polyester systems. Such chemicals should be treated as if they hurt your skin and eyes and as if they are poison to your body. For this reason, Magnum Venus Products recommends the use of protective clothing and eye wear in using polyester systems. However, users should be prepared in the event of such an injury.

Precautions include:

1. Know precisely what chemicals you are using and obtain information from your chemical supplier on what to do in the event the chemical gets onto your skin or into the eyes, or if swallowed.
2. Keep this information together and easily available so that it may be used by those administering first aid or treating the injured person.
3. Be sure the information from your chemical supplier includes instructions on how to treat any toxic effects the chemicals have.

**WARNING**

Contact your doctor immediately in the event of an injury. If the product's MSDS includes first aid instructions, administer first aid immediately after contacting a doctor.

Fast treatment of the outer skin and eyes that contact chemicals generally includes immediate and thorough washing of the exposed skin and immediate and continuous flushing of the eyes with lots of clean water for at least 15 minutes or more. These general instructions of first aid treatment may be incorrect for some chemicals; you must know the chemicals and treatment before an accident occurs. Treatment for swallowing a chemical frequently depends upon the nature of the chemical.

Emergency Stop Procedure

In an emergency, follow these steps to stop a system:

1. The ball valve located where the air enters the power head of the resin pump, should be moved to the “OFF” or closed position.

Note ***The “open” or “on” position is when the ball valve handle is parallel (in line) with the ball valve body. The “closed” or “off” position is when the ball valve handle is perpendicular (across) the ball valve body.***

2. Turn all system regulators to the “OFF” position (counter-clockwise) position.
3. Verify / secure the catalyst relief line, located on the catalyst relief valve.
4. Verify / secure the resin return line, located on the resin filter.
5. Place a container under the resin pump ball valve to catch ejected resin.
6. Locate the ball valve on the resin pump.
7. Rotate the ball valve 90 degrees to the “On” or open position.

Grounding

Grounding an object means providing an adequate path for the flow of the electrical charge from the object to the ground. An adequate path is one that permits charge to flow from the object fast enough that it will not accumulate to the extent that a spark can be formed. It is not possible to define exactly what will be an adequate path under all conditions since it depends on many variables. In any event, the grounding means should have the lowest possible electrical resistance.

Grounding straps should be installed on all loose conductive objects in the spraying area. This includes material containers and equipment. Magnum Venus Products recommends grounding straps be made of AWG No.18 stranded wire as a minimum and the larger wire be used where possible. NFPA Bulletin No77 states that the electrical resistance of such a leakage path should be 1 meg ohm (10^6 ohms) or less.



CAUTION

Whenever flammable or combustible liquids are transferred from one container to another, or from one container to the equipment, both containers or container and equipment shall be effectively bonded and grounded to dissipate static electricity. For further information, see National Fire Protection Association (NFPA) 77, titled “Recommended Practice on Static Electrical”. Refer especially to section 7-7 titled “Spray Application of Flammable and Combustible Materials”.

Introduction

This manual provides information for the operation, maintenance, and simple repair of the MVP Catalyst Alarm. The following procedures are included:

- Installation, start-up, and shut-down instructions
- Step-by-step operation instructions



Please read this manual carefully and retain for future reference. Follow the steps in the order given, otherwise you may damage the equipment or injure yourself.

The MVP Catalyst Alarm is a unique, safe, electrically powered catalyst flow alarm system for meter mix machinery. In operation, the Catalyst Alarm emits a clear audible whistle if the catalyst pump fails to deliver a full portion of catalyst to the gun. The unit is an entirely flow sensing device and will sense catalyst flow regardless of line pressures or cycle rates of ratio setting. No adjustment is needed by the operator.

Manufactured from grade 316 stainless steel, the fluid section flow manifold is rated to safe working pressures up to 170 bar (2500 psi).

The Catalyst Alarm system is supplied with all fittings needed to connect the air, fluid, and electrical circuit to an existing machine.



WARNING

This product was designed and tested for use with products common to the Fiberglass Reinforced Plastics (FRP) industry such as polyester resins, epoxy, urethanes, and vinyl esters. It has not been designed to work with other fluids, such as water.



Specifications

Dimensions	6in x 2.5in x 2in
Weight	5.25 lbs
Voltage Tolerance	100/240 VAC 50/60 HZ
Maximum Working Fluid Pressure	2500 PSI
Maximum Fluid Temp	100 ⁰ F / 37 ⁰ F
Wetted Parts	316 SS
Maximum Altitude	2000 m
Ingress Protection (IP) Rating	IP54
Pollution Degree	3

Listing Information

Listing Type	Reviewing Agency
US / CAN	MetLabs

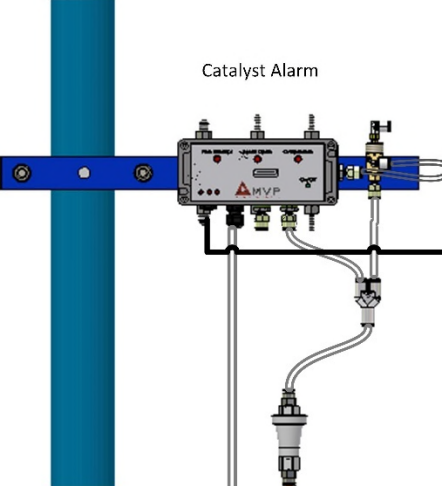

Safety Compliance Standards		
<p>UL61010-1/CSA C22.2 No. 61010-1</p>	<p>UL61010-1/CSA C22.2 No. 61010-1 ANSI/ISA-12.12.01-2015 CAN/CSA C22.2 No. 213-17</p>	<p>UL61010-1/CSA C22.2 No. 61010-1 UL 60079-0 Seventh Edition CSA C22.2 No. 60079-0:19 UL 60079-7 Fifth Edition CAN/CSA C22.2 No. 60079-7:16</p>
 <p>Power Supply</p> <p>12 VDC</p>	 <p>Catalyst Alarm</p>	 <p>Visual Indicator</p>

Unit Overview

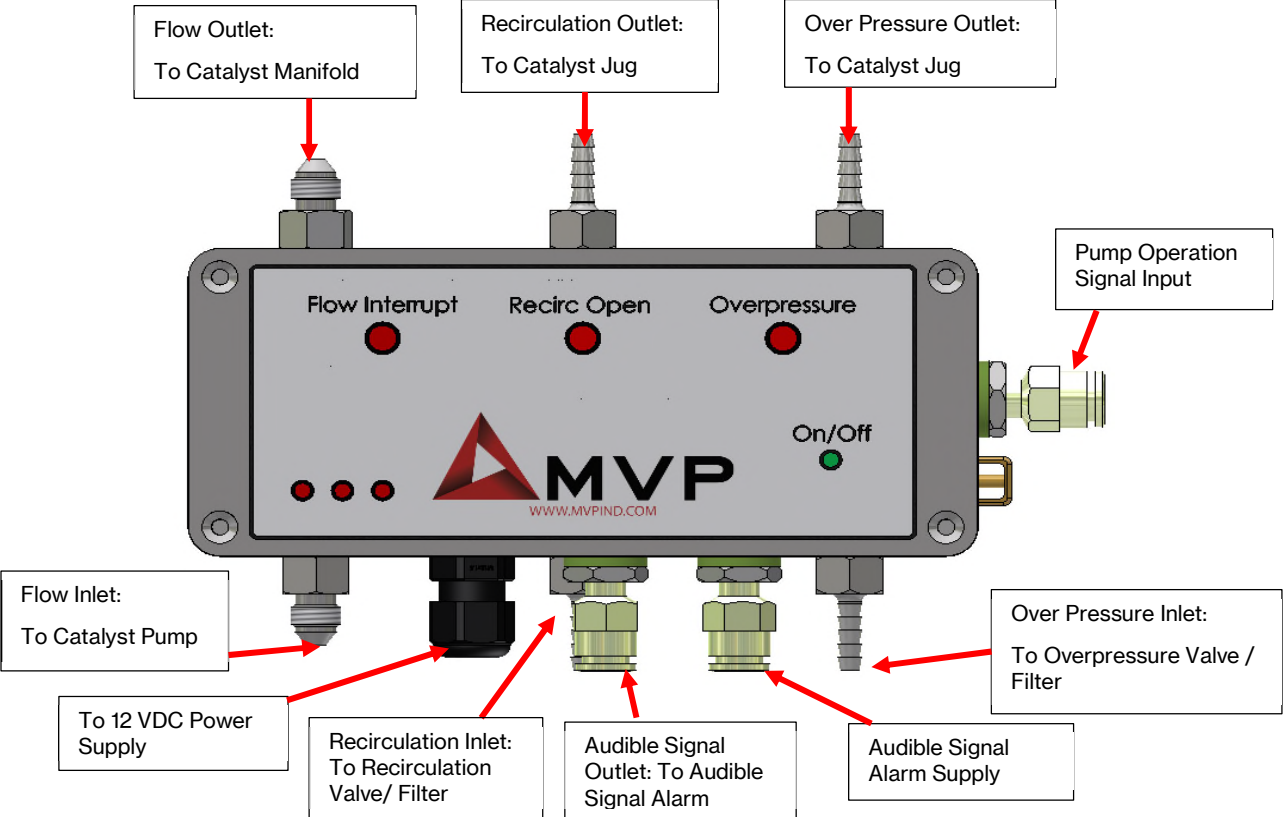

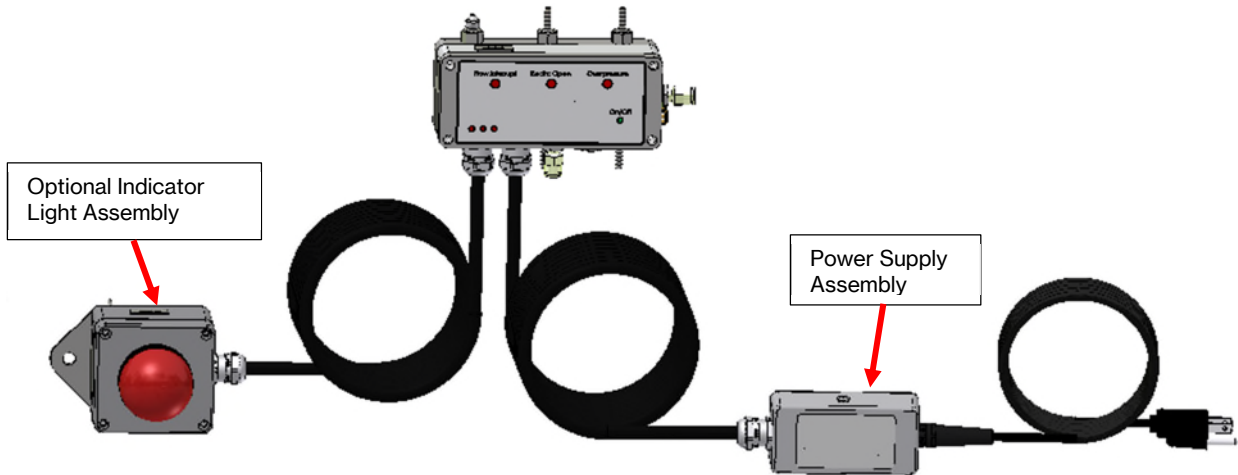

Installing Unit



WARNING

Wear the appropriate Personal Protective Equipment (PPE) during installation.

Important *The Cat Sense must always be VERTICALLY mounted in a suitable location on the spray system.*

Requirements

- The Catalyst Alarm requires use of the signal line from the powerhead valve end cap or a signal from the resin gun. The alarm can work from a T-fitting if an after-market counter is in use.
- Electrical outlet within 30 ft of the unit. Use supplied connector for US locations.



WARNING

Because of the variety of electrical codes in various parts of the world, MVP does not supply electrical connectors above 125 VAC. If you need a higher voltage, a qualified electrician should remove the existing plug and make the new electrical connection in accordance with the codes of the local jurisdiction. Failure to do so voids all warranty and liability directed at MVP or its subsidiaries.

The end user is responsible for ensuring that the end product or system complies with all relevant laws in the country where it is to be used and that all documentation is adhered to.

Note *The Catalyst Alarm can be installed in an open or enclosed environment.*



WARNING

This unit is rated IP54. It is not for use in wet locations.

Mount Unit

1. Attach the bracket with stiffening bar and mounting bar using hex bolts with lock washers and hex nuts.

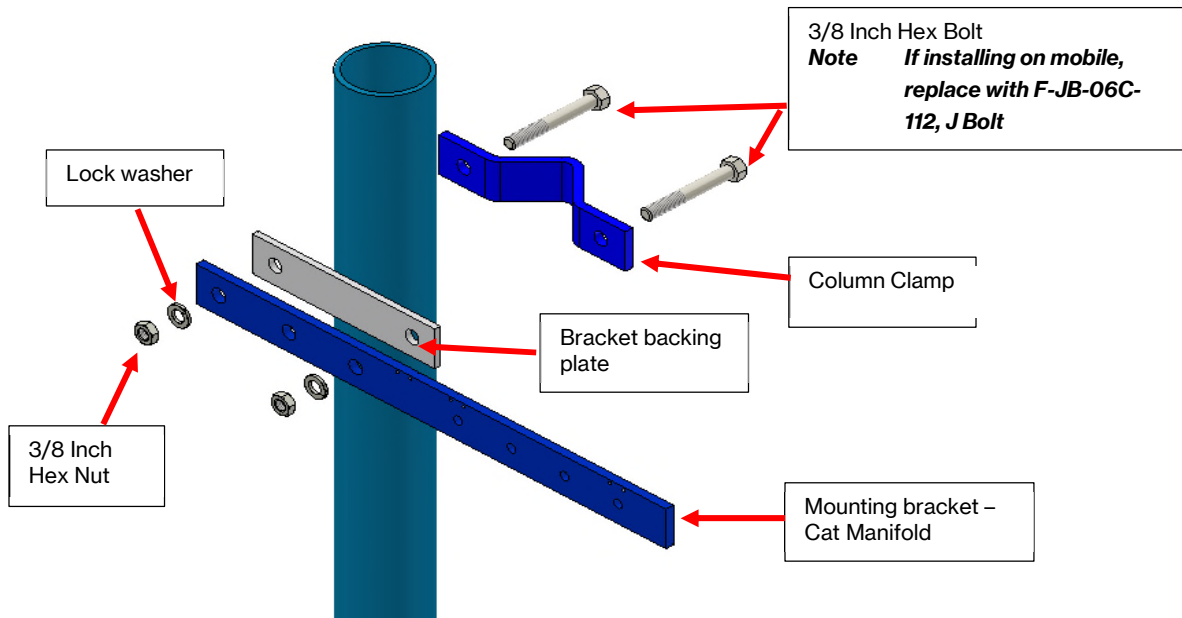

2. Torque the mounting bolts.
3. Install the Catalyst Alarm to the mounting bracket.

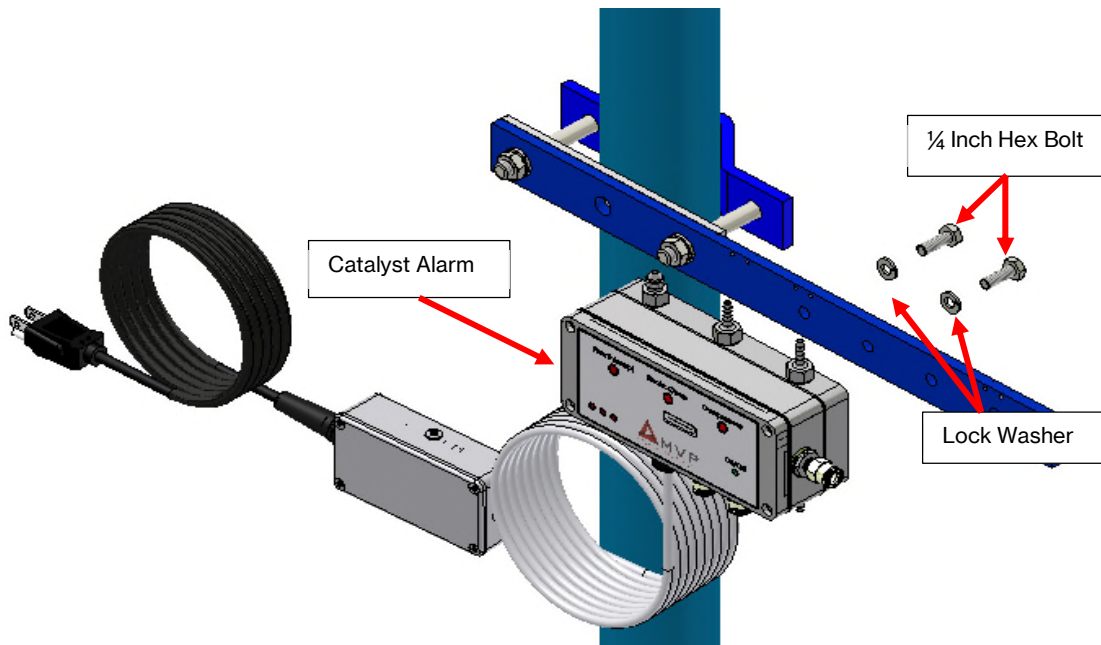

4. If you have the optional visual indicator, hang the light in the production area near the operator.

Note *The indicator light is mounted on a bracket that is designed to be easily relocated as necessary. How permanently you affix the bracket is your choice as long as the mounting hardware is rated for 10 pounds or more.*



WARNING

The nonconducting materials of the indicator light may be susceptible to ignition-capable level of electrostatic charging and precautions must be taken to avoid this. The user/installer shall ensure that the equipment is not installed in a location where it may be subjected to external conditions (such as high-pressure steam) which are conducive to creating a build-up of electrostatic charges.



WARNING

If the indicator light is likely to come into contact with aggressive substances (for example, acidic liquids or gases that may attack metals, or solvents that may affect polymeric materials), it is the responsibility of the user to take suitable precautions that prevent it from being adversely affected to ensure the type of protection is not compromised.

Use only a damp cloth to clean the indicator light.

5. Use a zip tie to attach the audible signal alarm to an appropriate surface in the production area near the operator.

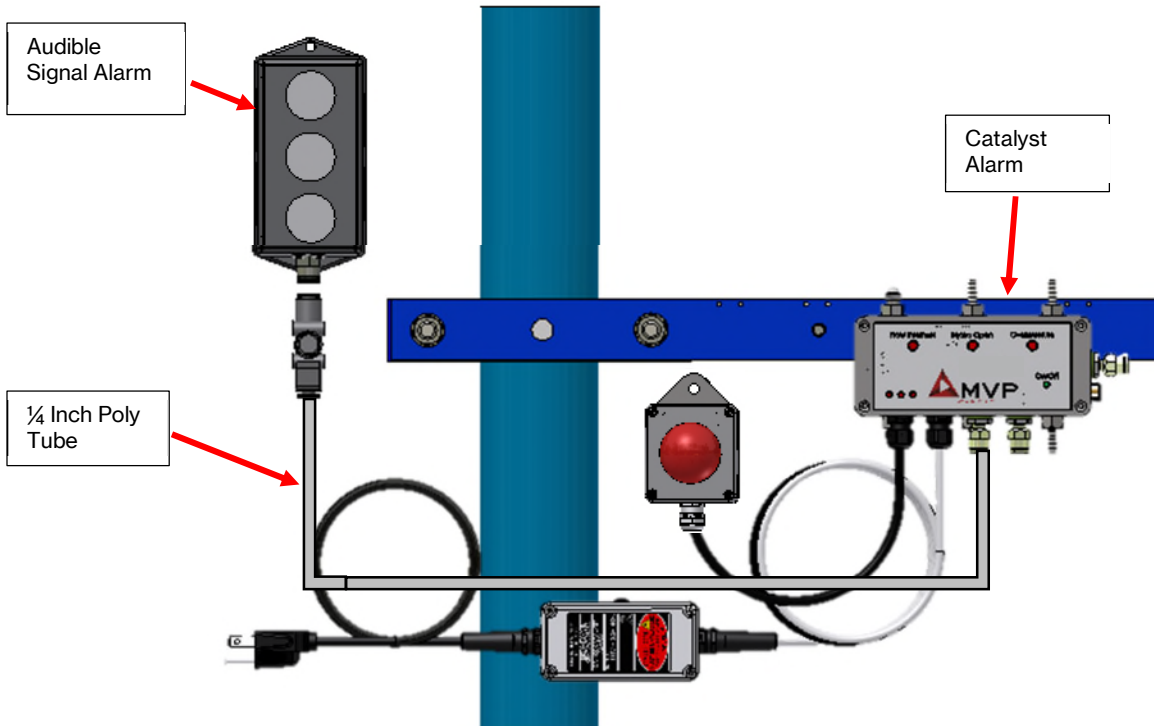

Note *Aim the audible signal alarm toward the operator.*

6. Feed ¼ inch poly tube from the Catalyst Alarm to the audible signal alarm.
7. Turn off the air supply to the system.

8. Cut the ¼ inch line to the power head switching valve.
9. Install a Y or T fitting in the ¼ inch line.
10. Install tubing from the inline pressure regulator, with the inlet side connecting to the fitting installed in the previous step and following the flow arrows to the audible signal alarm supply.
11. To install the overpressure valve, swap out the black plastic ring with the RV-1103-ADH drain ring and install the filter.

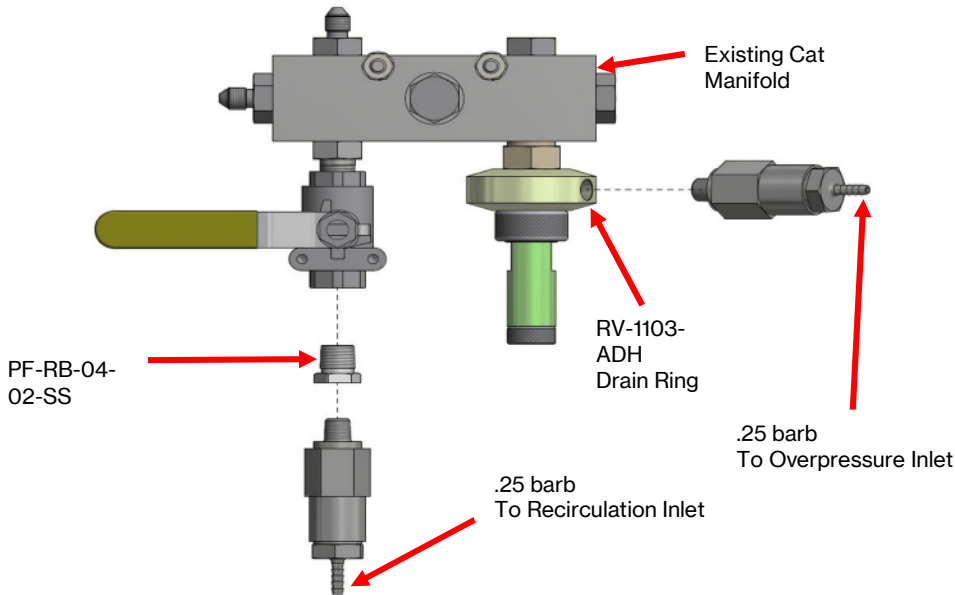

12. Remove the fitting on the bottom of the recirculation valve and install the reducer bushing and filter.
13. Connect clear ¼ inch poly tubing as follows:
 - From the recirculation inlet on the Catalyst Alarm to the recirculation filter
 - From the overpressure inlet on the Catalyst Alarm to overpressure filter
 - From the recirculation alarm outlet to the catalyst jug
 - From the overpressure outlet to the catalyst jug
14. Locate the metal braided hose from the catalyst pump and disconnect it from the catalyst manifold.
15. Connect the braided hose to the flow inlet.
16. Run blue HP hose from the flow outlet to the catalyst manifold.

Powerhead Install

17. If you are using the gun signal, skip to step [22](#).
18. Remove Allen screw from the top of the powerhead valve end cap.
19. Install poly elbow.

20. Connect ¼ inch poly tube to the poly elbow and to the pump operation signal on the Catalyst Alarm.

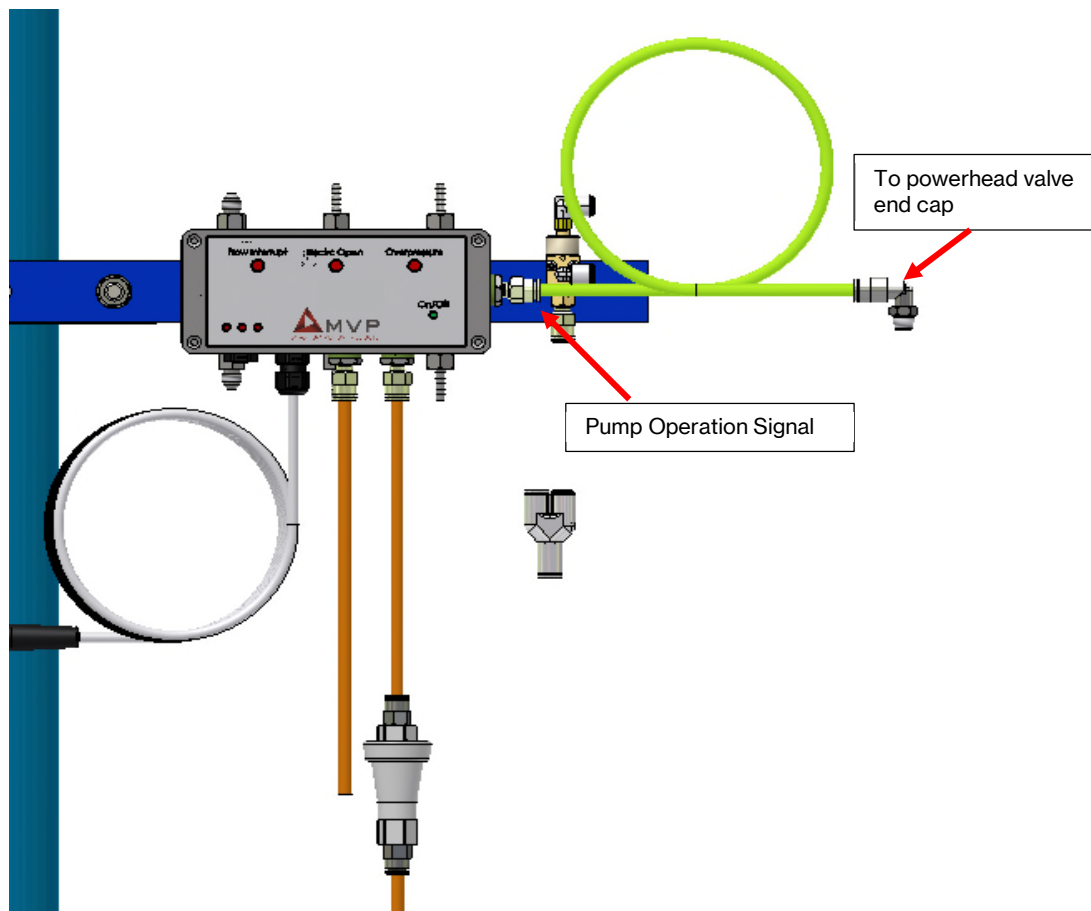

21. Skip to the Power Up Alarm steps.

Gun Signal Install

22. Install operation valve onto the mounting bar.
23. Install ¼ inch poly tube from:
- Pump operation signal input to outlet 2 of operation valve
 - Inline pressure regulator outlet to bottom of Y union
 - One split of Y union to Audible Alarm Signal Supply
 - One split of Y union to 1/8" NPT inlet 1 of operation valve
 - Inlet of operation valve to gun

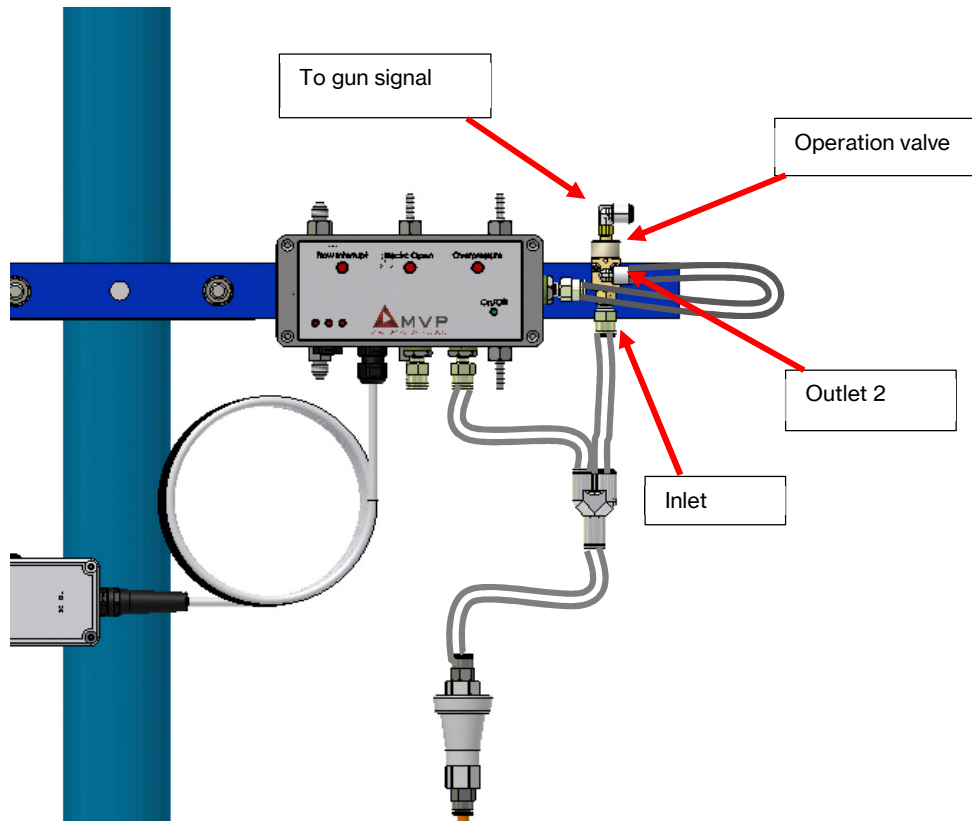

Power Up Alarm

24. Energize the Catalyst Alarm circuit by plugging into an outlet.

Note *The Catalyst Alarm can be turned off by unplugging the power cord during production without an impact. The Cat Sense fluid manifold only monitors fluid flow and does not block or impede it.*

25. Turn on the air supply to the system.

Note *The Cat Sense is supplied with a ¼ inch mini regulator. The air pressure supplied to the regulator should be set between 50 and 120 psi for correct operation of the Catalyst Alarm.*

26. Once the Cat Sense has been installed and securely mounted, open the recirculation valve and prime catalyst as normal to remove air from the catalyst system.

Note *Contact your nearest MVP Technical Service Representative or reference the operations manual for your unit for additional information if needed.*

The Catalyst Alarm has been designed and tested to work with MVP products in enclosed (indoor) environments that are well ventilated.



WARNING

The Catalyst Alarm should not be installed or used near open flames, sparks, or flammable storage material.



CAUTION

The Catalyst Alarm should only be used on grounded electrical circuits/equipment.

The end user is responsible for ensuring that the product or system complies with all of the relevant laws in the country where it is to be used and that all documentation is adhered to.

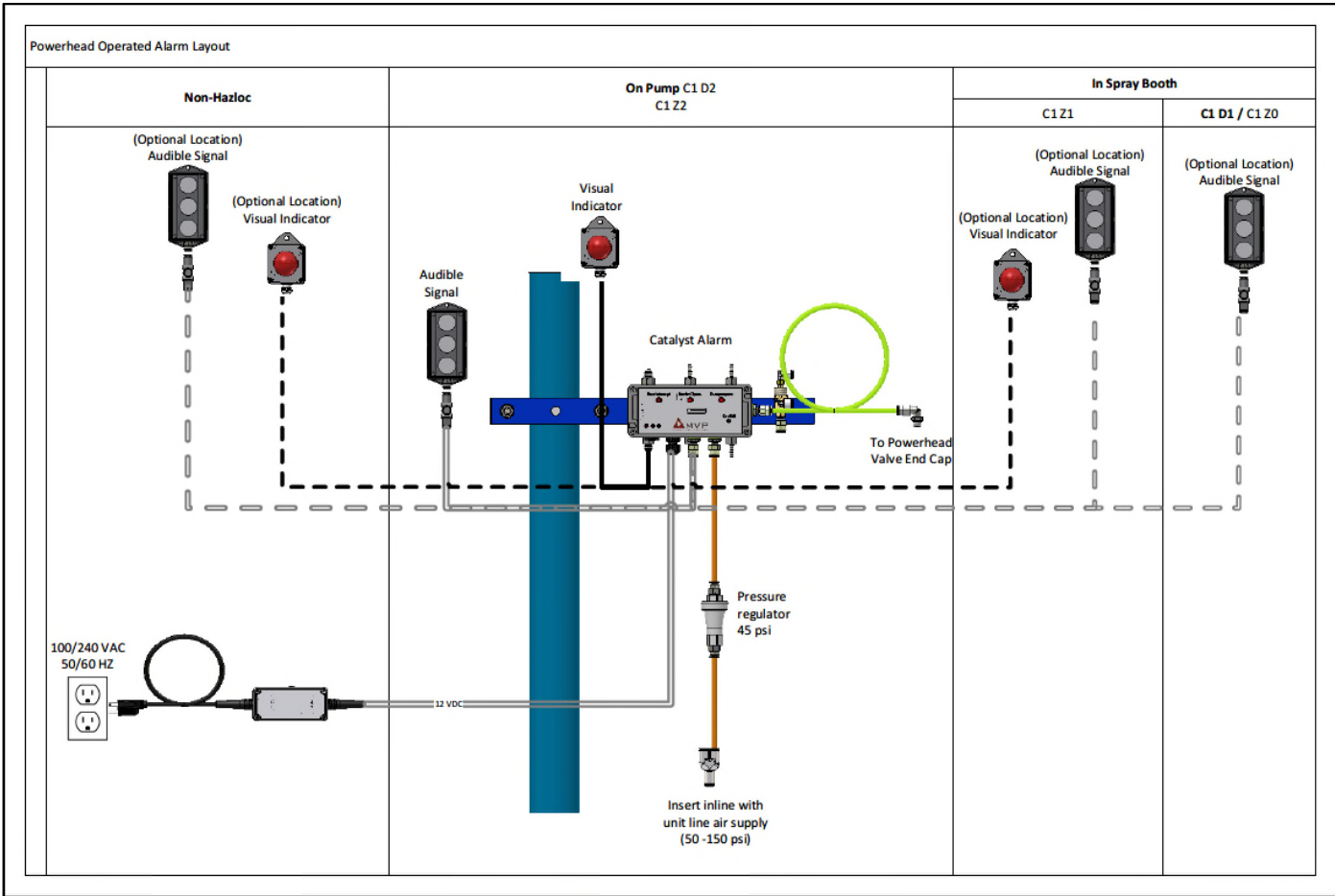

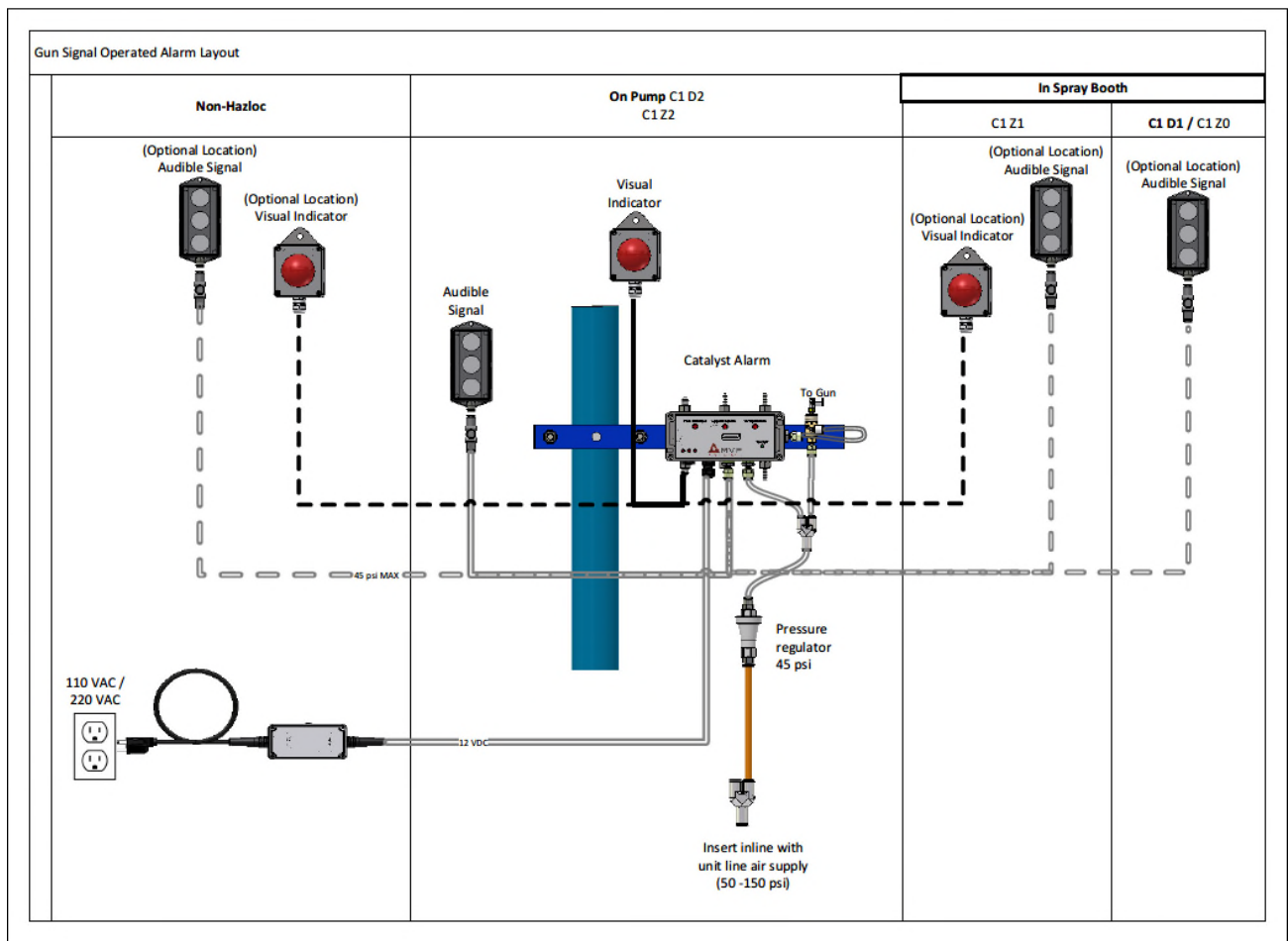

Setting Up and Configuring

1. Ensure alarm is unplugged.
2. Remove cover by loosening the 4 mounting screws at each corner.
3. Depress the clip for the electronic connection to the cover and gently pull to disconnect the cover.
4. Set gun/powerhead operation to:
 - Gun (Up) if pump operation signal input is connected to operation valve
 - Powerhead (Down) if pump operation signal input is connected to top of powerhead

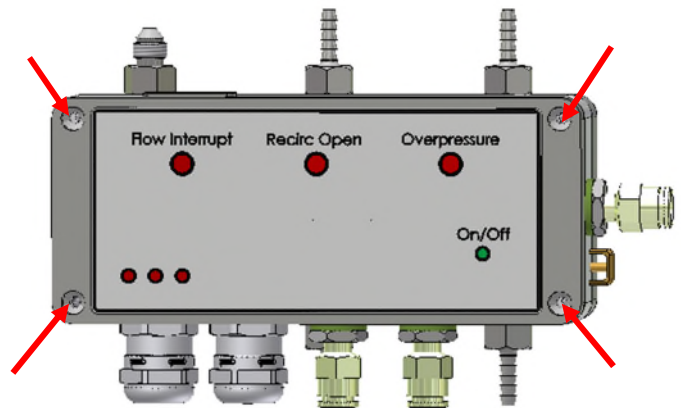

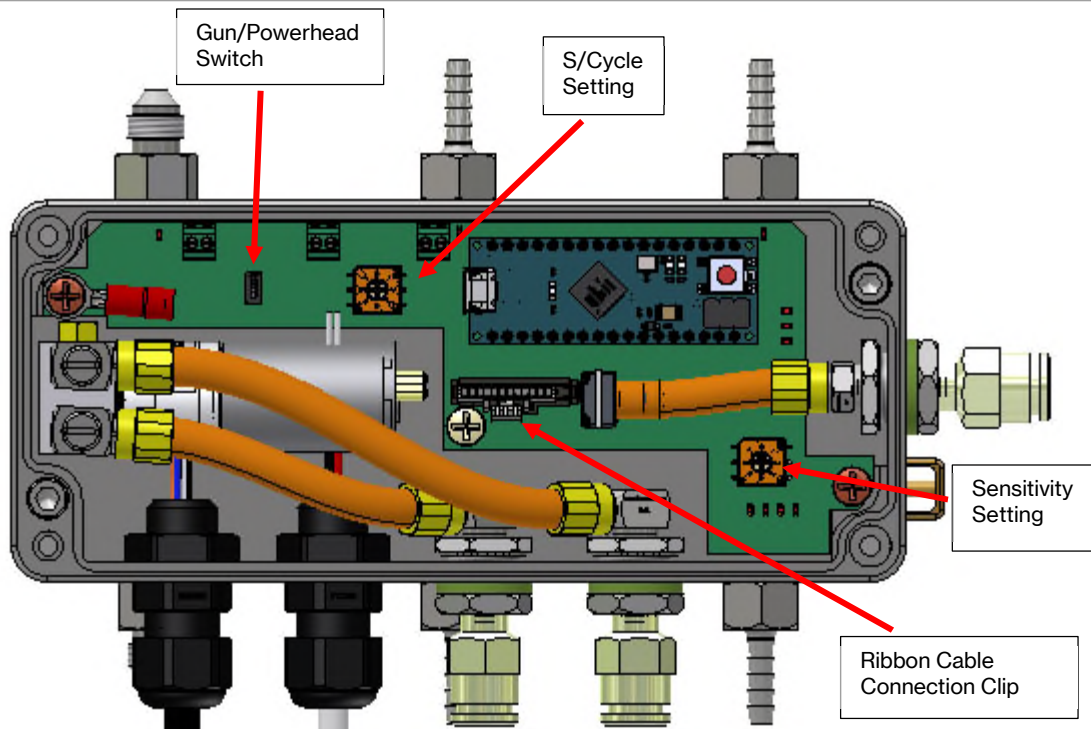

5. If gun option is used, measure and set pump cycle time by doing the following:
 - Measure the number of seconds it takes for the pump to cycle down and back up
 - Round up to the next whole number
 - Set s/cycle setting to the whole number
6. Set the sensitivity:
 - To 0 or 1 for external mix
 - From 4 to 7 for internal mix

Note ***A lower sensitivity will result in more alarms, but will help to predict when a catalyst pump or pump system requires service.***

Operating Catalyst Alarm

1. Plug the alarm in.
2. Open the recirculation valve.
3. Prime the catalyst pump by hand until all air is purged from the system.
4. Close the recirculation valve.
5. Pressurize the system by hand.
6. Ensure that the three flow signal lights on the alarm are not illuminated before beginning operation.

Note ***Flow signal lights should not be illuminated when pump is not running.***

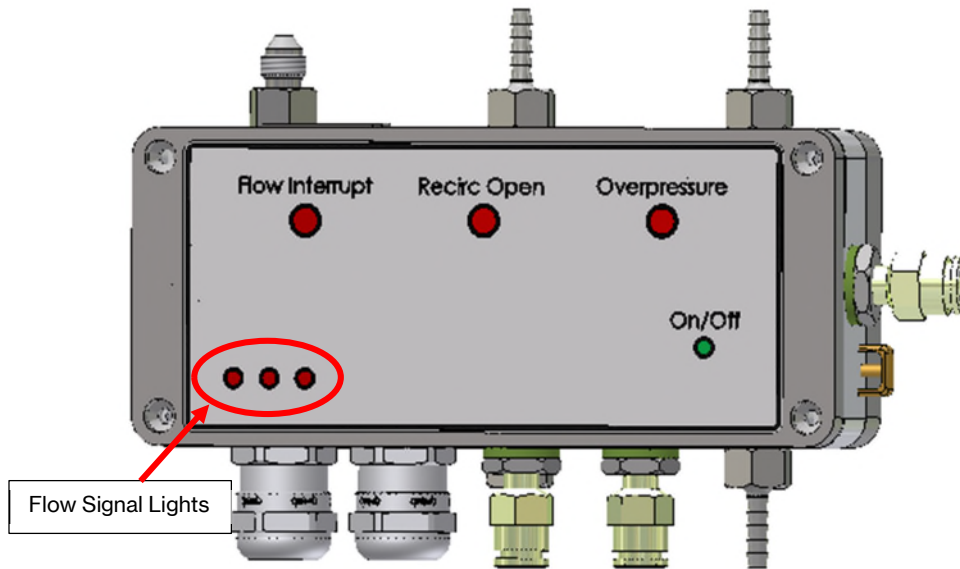

If the alarm goes off, continue with the following steps:

7. Release the gun trigger.
8. Check the status of the Catalyst Alarm.
9. Address any/all status alarms.
10. Continue operation; alarm will clear once operation is resumed.

Performing Maintenance

1. Turn off and unplug electrical equipment associated with the system.
2. Put on proper safety gear, gloves, and safety glasses.
3. Open the recirculation valve to relieve pressure.
4. Remove catalyst supply.
5. Prime the catalyst pump until air bubbles are seen on the recirculation outlet line.
6. Clean all tools to be used; making sure they are free of grease or any other material that may react with organic peroxides.

Every Six Months

7. Use wrench to remove top fittings from fluid manifold.
8. Remove magnetic floats using clean metallic rod or screwdriver.

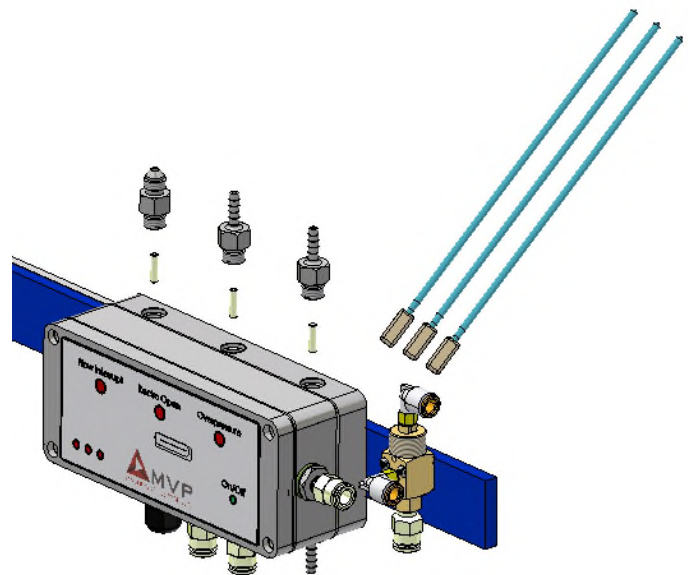

9. Using a swab provided in the cleaning kit, slowly spin swab as you insert and remove from each fluid manifold flow tube.
10. Disassemble the barb fittings and clean the filters of any debris.

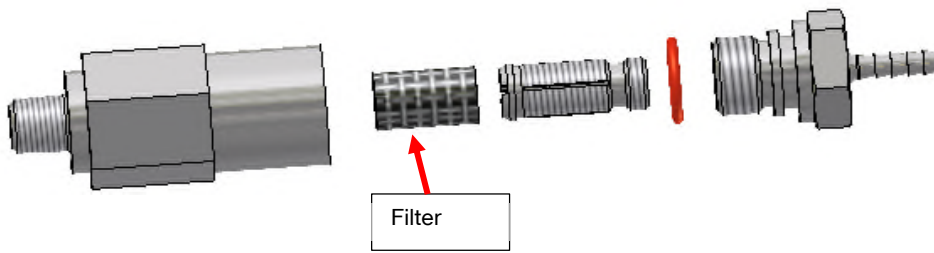

As Needed

11. Replace mesh inside the filter, if damaged.

Troubleshooting

Common Issues and Solutions			
Problem	Cause	Solution	
Flow Interrupt Alarm	Empty Catalyst	Fill catalyst supply, purge air from system	
	Air in catalyst pump	Open recirculation valve and purge system by operating slave arm by hand	
	Rapid on/off cycling of pump		Re-train operators to use system during constant operation
			Switch to gun operated configuration
	Sensitivity setting too low (low numbers = greater sensitivity)	Increase sensitivity setting number	
	Catalyst pump not checking off quickly	Rebuild catalyst pump	
	Slave arm pin is missing	Install slave arm pin	
	Debris in catalyst alarm flow manifold	Clean manifold	
Recirculation alarm	Recirculation valve open	Close valve	
	Debris in catalyst alarm flow manifold	Clean manifold	
Overpressure alarm	System overpressure	Inspect lines and gun for clogs	
	Overpressure valve is faulty	Rebuild overpressure valve	
	Debris in manifold	Clean manifold	
Alarm does not sense an empty / recirculation / overpressure fault	No power applied	Plug in an ensure green power light is on	
	Debris in flow manifold	Clean manifold	
	Configuration settings are incorrect	Review configuration section and reset all switches	

Common Issues and Solutions		
Problem	Cause	Solution
Material flow blockage or leak	Cat sense assembly is leaking	Inspect O-rings and replace as needed
	Cat sense assembly is leaking	Check that top and bottom fittings of flow manifold are correctly tightened and O-rings are serviceable.
	Cat sense is blocked	Remove assembly and thoroughly clean
Indicator light not functioning	Device failure	Replace light assembly Note Do not attempt repairs to this device; it contains no field-replaceable parts or components

System Components

The Catalyst Alarm must be serviced with original equipment manufacturer (OEM) components supplied by MVP to maintain certification. For additional information about parts, visit our website at <http://www.mvpind.com/application-support/technical-documents/>.

Core System Parts	
Part Number	Description
COL-CLMP	Column Clamp
F-SW-06	Lock Washer
F-HN-06C	Hex Nut
F-SW-04-SS	Lock Washer
F-HB-04C-12-SS	¼ Hex Bolt
RV-1103-ADH	Drain Ring
ECA-BRKT-MB-1	Alarm Mount Bracket
MCF-1000-02-BT	Catalyst Filter Assembly
ECA-5100	Catalyst Alarm Core without Indicator Light
ECA-5100-IND	Catalyst Alarm Core with Indicator Assembly (Optional)
ECA-5200	Audible Alarm Assembly
MS-2052-1	Natural Polytube
07223	Male Connector
MPH-2539	Male Elbow
01444	Green Polytube (4 Ft)
HCHP-023J3J-6	Catalyst Hose
ECA-BRKT-MB-2	Backing Plate
F-HB-06C-44	Hex Bolt
PNE-IPR-101	Regulator 45 Psi
01449	Orange Polytube (5 Ft)
PF-RB-04-02-SS	Reducer Bushing
PNE-POP-101	Poppet Valve
06867	Elbow

Core System Parts	
Part Number	Description
06977	Fitting
F-BHCS-440-14	Button Head Cap Screw
PNE-FCV-103	Flow Control Valve
06946	Y Union
01449	Orange Polytube (50 Ft)
ECA-5000-CL-K	Cleaning Kit
F-JB-06C-112	J Bolt
ECA-PWR-100	Catalyst Alarm Power Box Assembly

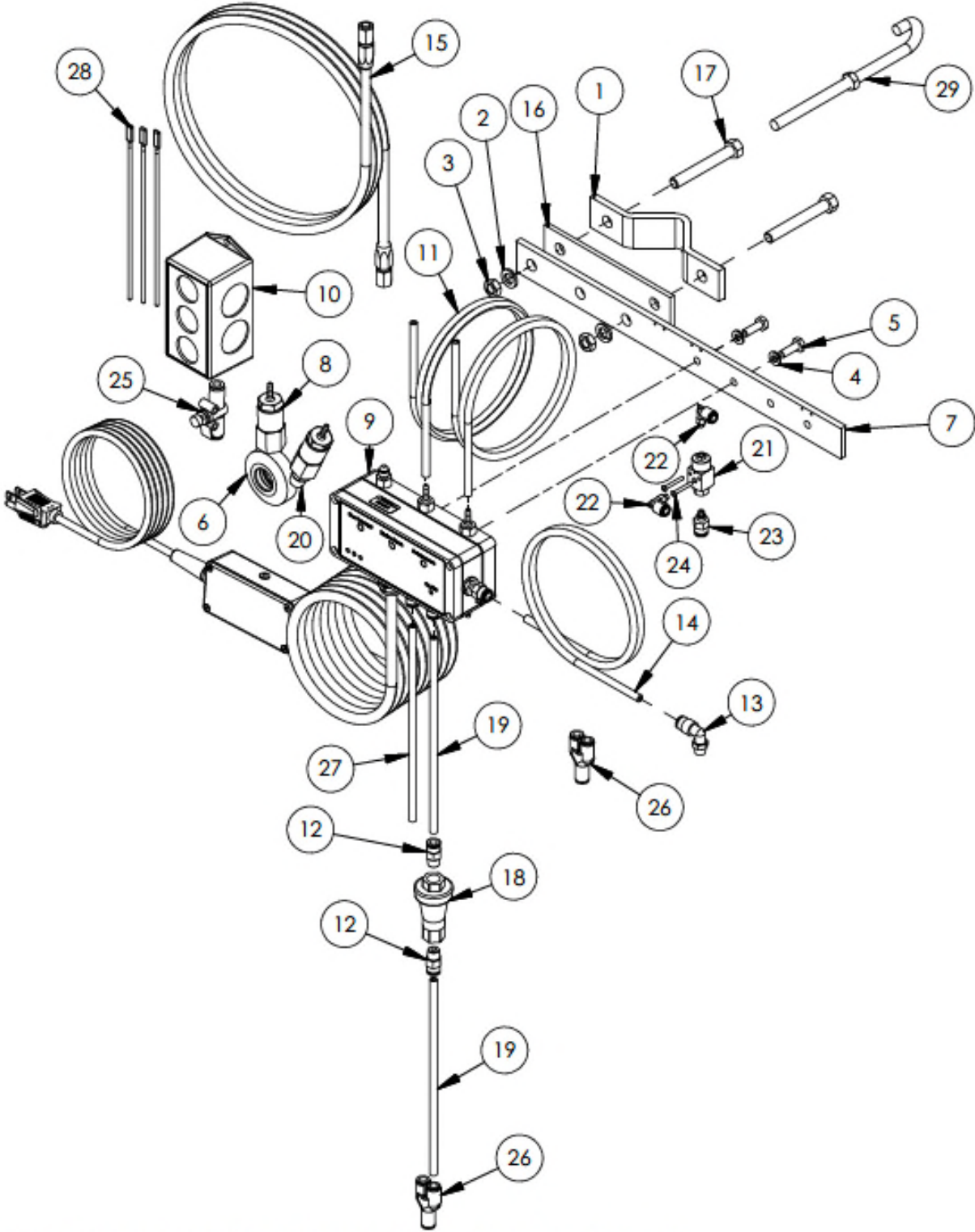

MAGNUM VENUS PRODUCTS

CATALYST ALARM KIT	ECA-5000
--------------------	----------

REV:A

SHEET 1 / 2

12/17/2019



Parts List			
ITEM	PART NUMBER	QTY	DESCRIPTION
1	COL-CLMP	1	COLUMN CLAMP
2	F-SW-06	2	LOCK WASHER
3	F-HN-06C	2	HEX NUT
4	F-SW-04-SS	2	LOCK WASHER
5	F-HB-04C-12-SS	2	1/4 HEX BOLT
6	RV-1103-ADH	1	DRAIN RING
7	ECA-BRKT-MB-1	1	ALARM MOUNT BRACKET
8	MCF-1000-02-BT	2	CATALYST FILTER
9	ECA-5100	1	CATALYST ALARM CORE
10	ECA-5200	1	AUDIBLE ALARM ASSEMBLY
11	MS-2052-1	2	NATURAL POLYTUBE
12	07223	2	MALE CONNECTOR
13	MPH-2539	1	MALE ELBOW
14	01444	1	GREEN POLYTUBE (4 FT)
15	HCHP-023J3J-6	1	CATALYST HOSE
16	ECA-BRKT-MB-2	1	BACKING PLATE
17	F-HB-06C-44	2	HEX BOLT
18	PNE-IPR-101	1	REGULATOR 45 PSI
19	01449	2	ORANGE POLYTUBE (5 FT)
20	PF-RB-04-02-SS	1	REDUCER BUSHING
21	PNE-POP-101	1	POPPET VALVE
22	06867	2	ELBOW
23	06977	1	FITTING
24	F-BHCS-440-14	2	BUTTON HEAD CAP SCREW
25	PNE-FCV-103	1	FLOW CONTROL VALVE
26	06946	2	Y UNION
27	01449	1	ORANGE POLYTUBE (50 FT)
28	ECA-5000-CL-K	1	CLEANING KIT
29	F-JB-06C-112	1	J BOLT

REPAIR PARTS:

- * ECA-5000-CL-K CLEANING KIT
- * ECA-5005-01 MAGNETIC FLOAT

MAGNUM VENUS PRODUCTS

CATALYST ALARM KIT

ECA-5000

REV:A

SHEET 2 / 2

12/17/2019

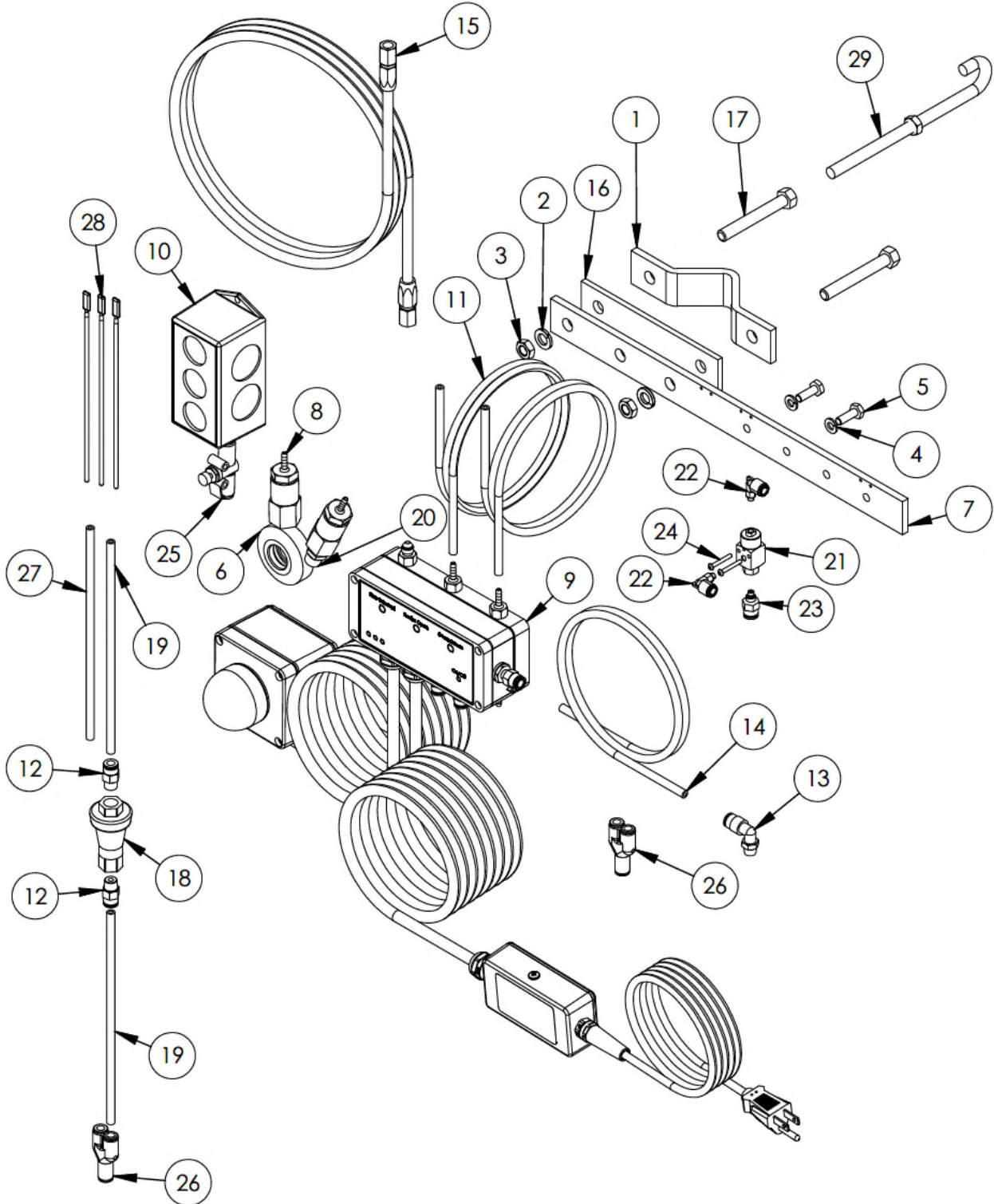

MAGNUM VENUS PRODUCTS

CATALYST ALARM WITH VISUAL INDICATOR ECA-5000-IND

REV:A

SHEET 1 / 2

12/17/2019



Parts List			
ITEM	PART NUMBER	QTY	DESCRIPTION
1	COL-CLMP	1	COLUMN CLAMP
2	F-SW-06	2	LOCK WASHER
3	F-HN-06C	2	HEX NUT
4	F-SW-04-SS	2	LOCK WASHER
5	F-HB-04C-12-SS	2	1/4 HEX BOLT
6	RV-1103-ADH	1	DRAIN RING
7	ECA-BRKT-MB-1	1	ALARM MOUNT BRACKET
8	MCF-1000-02-BT	2	CATALYST FILTER
9	ECA-5100-IND	1	CATALYST ALARM CORE WITH INDICATOR
10	ECA-5200	1	AUDIBLE ALARM ASSEMBLY
11	MS-2052-1	2	NATURAL POLYTUBE
12	07223	2	MALE CONNECTOR
13	MPH-2539	1	MALE ELBOW
14	01444	1	GREEN POLYTUBE (4 FT)
15	HCHP-023J3J-6	1	CATALYST HOSE
16	ECA-BRKT-MB-2	1	BACKING PLATE
17	F-HB-06C-44	2	HEX BOLT
18	PNE-IPR-101	1	REGULATOR 45 PSI
19	01449	2	ORANGE POLYTUBE (5 FT)
20	PF-RB-04-02-SS	1	REDUCER BUSHING
21	PNE-POP-101	1	POPPET VALVE
22	06867	2	ELBOW
23	06977	1	FITTING
24	F-BHCS-440-14	2	BUTTON HEAD CAP SCREW
25	PNE-FCV-103	1	FLOW CONTROL VALVE
26	06946	2	Y UNION
27	01449	1	ORANGE POLYTUBE (50 FT)
28	ECA-5000-CL-K	1	CLEANING KIT
29	F-JB-06C-112	1	J BOLT

REPAIR PARTS:

- *ECA-5000-CL-K CLEANING KIT
- *ECA-5005-01 MAGNETIC FLOAT

MAGNUM VENUS PRODUCTS

CATALYST ALARM WITH VISUAL INDICATOR

ECA-5000-IND

REV:A

SHEET 2 / 2

12/17/2019

Warranty

Product Warranty

Seller warrants that all Goods sold shall mechanically operate as specified and shall be free from faults in respect to materials and workmanship for a period of: (i) for parts, twelve (12) months from the date of invoice, and (ii) for systems, twelve (12) months from start-up, or, if earlier, eighteen (18) months from the date of the bill of lading. Seller also warrants that the Goods shall, upon payment in full by Buyer for the Goods, be free and clear of any security interests or liens. Buyer's exclusive remedy for breach of such warranties shall be limited to repair or replacement costs or termination of any security interests or liens, and Seller shall have no responsibility for reimbursing repair costs incurred by Buyer in connection with Goods without first giving written authorization for such charges. In any claims by the Buyer against the Seller in respect of the Goods, the liability of the Seller shall be limited to the value of the Goods. This warranty applies only to Goods properly used and maintained and does not apply to any Goods which are misused or neglected, or which has been installed, operated, repaired, altered or modified other than in accordance with instructions or written authorization by Seller. This warranty does not apply to any Goods not manufactured by Seller, and Buyer's sole warranty with respect to such Goods shall be that of the Seller's Vendor, if any.

Vendor Warranty

Seller shall assign to Buyer any Vendor warranties and/or remedies provided to Seller by its Vendor.

Intellectual Property Infringement

Seller disclaims any and all warranties and/or indemnifications against infringement of any intellectual property rights of any nature. Seller shall, if given prompt notice by buyer of any claim of intellectual property infringement with respect to any goods sold hereunder, request the applicable vendor to grant for the buyer such warranty or indemnity rights as such vendor may customarily give with respect to such goods.

Limitations

There are no other warranties written or oral, express, implied or by statute. Seller specifically disclaims all implied warranties of merchantability or fitness for a particular purpose. No repair of goods or other costs are assumed by seller unless agreed to, in advance, in writing.

Limitations of Liability

Unless applicable law otherwise requires, seller's and any vendor's total liability to buyer, buyer's customers or to any other person, relating to any purchases governed by these terms & conditions, from the use of the goods furnished or from any advice, information or assistance provided by seller (by any method, including a web site), is limited to the price of the goods giving rise to the claim. Neither seller nor its vendors shall be liable for any special, incidental, direct, consequential or penal damages, including, but not limited to back-charges, labor costs, costs of removal, replacement, testing or installation, loss of efficiency, loss of profits or revenues, loss of use of the goods or any associated goods, damage to associated goods, lateness or delays in delivery, unavailability of goods, cost of capital, cost of substitute goods, facilities or services, downtime, or claims from buyer's customers or other parties. If seller furnishes buyer with advice or other assistance which concerns any goods supplied hereunder, or any system or equipment in which any such goods may be installed, and which is not required pursuant to these terms & conditions, the furnishing of such advice or

assistance will not subject seller to any liability, whether based on contract, warranty, tort (including negligence) or other grounds.

Warranty and Exceptions

Electrical connections for 220 VAC operation should be made by a qualified electrician per codes of local jurisdiction.



CORPORATE HEADQUARTERS

2030 Falling Waters Rd, Suite 350, Knoxville, TN 37922 · USA · Tel: (865) 686-5670

DISTRIBUTION AND PURCHASING

642 Barbrow Ln, Knoxville, TN 37932 · USA · Tel: (865) 684-4416

TECHNOLOGY CENTER AND MANUFACTURING

1862 Ives Ave, Kent, WA 98032 · USA · Tel (253) 854-2660 · Fax (253) 854-1666

E-mail: info@mvpind.com

For a list of international distributors, visit our website at :

www.mvpind.com/mvp-international