

Cartridge Filling Station

Operations Manual

This manual is applicable to the following models:

- IMA-CCP-ADH-CFSA
- IMA-CCP-ADH-CFSB
- IMA-CCP-ADH-CFS-C
- IMA-CCP-ADH-CFS-E

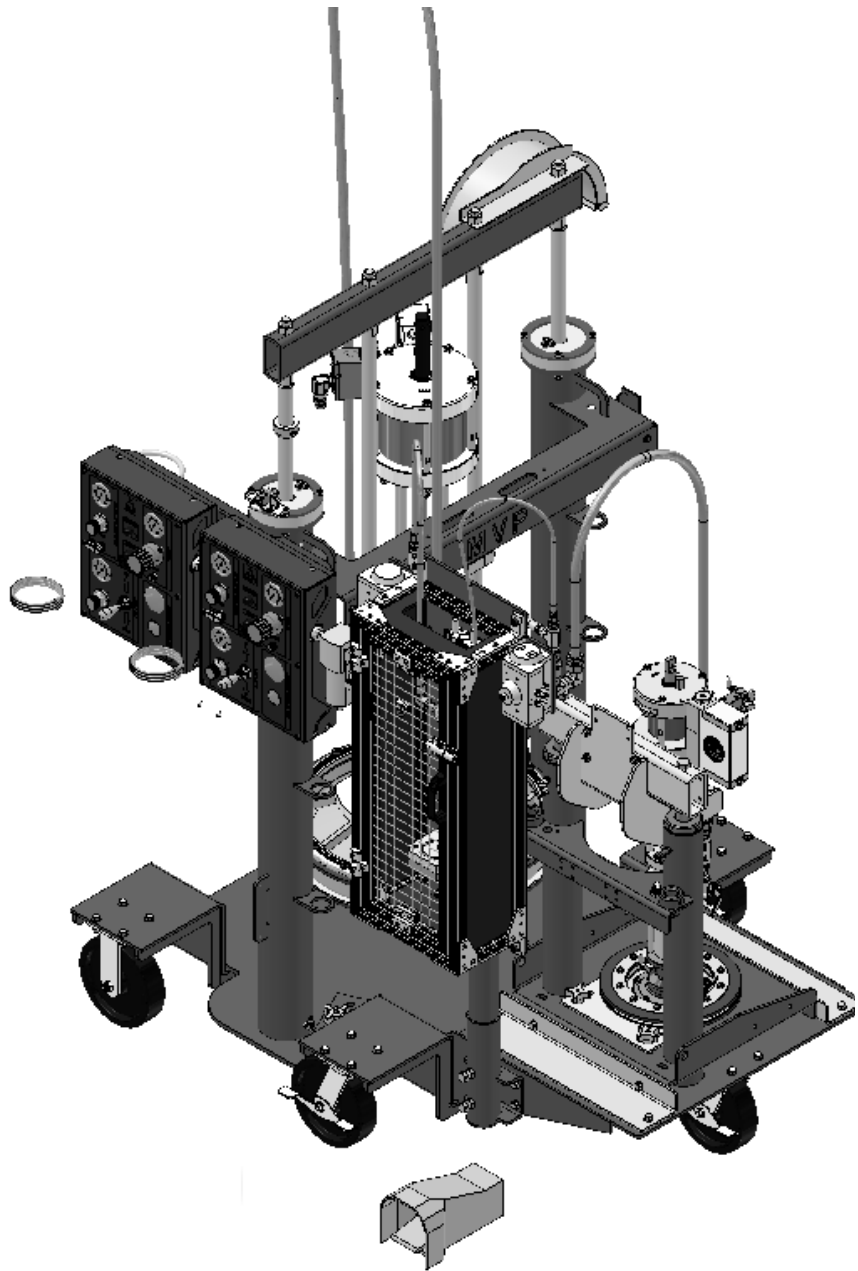

Rev. September 2019



CORPORATE HEADQUARTERS

2030 Falling Waters Rd, Suite 350, Knoxville, TN 37922 · USA · Tel: (865) 686-5670

DISTRIBUTION AND PURCHASING

642 Barbrow Ln, Knoxville, TN 37932 · USA · Tel: (865) 684-4416

TECHNOLOGY CENTER AND MANUFACTURING

1862 Ives Ave, Kent, WA 98032 · USA · Tel (253) 854-2660 · Fax (253) 854-1666

E-mail: info@mvpind.com

For a list of international distributors, visit our website at :

www.mvpind.com/mvp-international

Use of this product confirms that Magnum Venus Products, Inc.'s standard terms and conditions of sale apply.

Table of Contents

| Section | Page |
|---|-------------|
| • Table of Contents | 3 |
| • Safety & Warning Information | 4 |
| • Introduction | 15 |
| • Getting Started | 19 |
| • Adjusting the Fill Station | 21 |
| • Filling Cartridges | 22 |
| • Changing an Empty Drum/Pail | 23 |
| • Performing Daily Procedures | 24 |

Safety & Warning Information

Warnings

Due to the vast number of chemicals that could be used and their varying chemical reactions, the buyer and user of this equipment should determine all factors relating to the fluids used, including any of the potential hazards involved. Particular inquiry and investigation should be made into potential dangers relating to toxic fumes, fires, explosions, reaction times, and exposure of human beings to the individual components or their resultant mixtures. MVP assumes no responsibility for loss, damage, expense or claims for bodily injury or property damage, direct or consequential, arising from the use of such chemical components.

The end user is responsible for ensuring that the end product or system complies with all the relevant laws in the country where it is to be used and that all documentation is adhered to.

Recommended Occupational Safety & Health Act (OSHA) Documentation:

- 1910.94 Pertaining to ventilation
- 1910.106 Pertaining to flammable liquids
- 1910.107 Pertaining to spray finishing operations, particularly paragraph (m), Organic Peroxides and Dual Component Coatings

For Additional information, contact the Occupational Safety and Health Administration (OSHA) at <https://www.osha.gov/about.html>.

Recommended National Fire Protection Association (NFPA) Documentation:

- NFPA No.33 Chapter 14 Organic Peroxides and Dual Component Materials
- NFPA No. 63 Dust Explosion Prevention
- NFPA No. 70 National Electrical Code
- NFPA No. 77 Static Electricity
- NFPA No. 91 Blower and Exhaust System
- NFPA No. 654 Plastics Industry Dust Hazards

Fire Extinguisher – code ABC, rating number 4a60bc using Extinguishing Media –Foam, Carbon Dioxide, Dry Chemical, Water Fog, is recommended for this product and applications.

The following general warnings and guidelines are for the setup, use, grounding, maintenance, and repair of equipment. Additional product-specific warnings may be found throughout this manual as applicable. Please contact your nearest MVP Technical Service Representative if additional information is needed.

Safety Precautions

- Avoid skin contact and inhalation of all chemicals.
- Review Material Safety Data Sheet (MSDS) to promote the safe handling of chemicals in use.
- Restrict the use of all chemicals to designated areas with good ventilation.
- Chemicals are flammable and reactive.
- Noxious fumes released when combusted.
- Operate equipment in a ventilated environment only.
- Uncured liquid resins are highly flammable unless specifically labeled otherwise.
- Cured laminate, accumulations of overspray, and laminate sandings are highly combustible.
- Do not operate or move electrical equipment when flammable fumes are present.
- Ground all equipment.
- If a spark is seen or felt, immediately halt operation. Do not operate the equipment until the issue has been identified and repaired.
- Contaminated catalyst may cause fire or explosion.
- Containers may explode if exposed to fire / heat.
- Use and store chemicals away from heat, flames, and sparks.
- Do not smoke in work areas or near stored chemicals.
- Do not mix Methyl Ethyl Ketone Peroxide (MEKP) with materials other than polyethylene.
- Do not dilute MEKP.
- Keep food and drink away from work area.



Physical Hazards

- Never look directly into the spray gun fluid tip. Serious injury or death can result.
- Never aim the spray gun at or near another person. Serious injury or death can result.
- Chemical compounds can be severely irritating to the eyes and skin.
- Inhalation, ingestion, or injection may damage internal organs and lead to pulmonary disorders, cancers, lymphomas, and other diseases or health conditions.
- Other potential health effects include: irritation of the eyes and upper respiratory tract, headache, light-headedness, dizziness, confusion, drowsiness, nausea, vomiting, and occasionally abdominal pain.
- Eye contact: Immediately flush with water for at least 15 minutes and seek immediate medical attention.
- Skin Contact: Immediately wash with soap and water and seek immediate medical attention.
- Inhalation: Move the person to fresh air and seek immediate medical attention.
- Do not remove shields, covers, or safety features on equipment that is in use.
- Never place fingers, hands, or any body part near or directly in front of the spray gun fluid tip. The force of the liquid as it exits the spray tip can shoot liquid through the skin.
- Keep hands and body parts away from any moving equipment or components.
- Do not stand under plunger
- An improperly loaded drum may lead to an imbalance, causing a unit to tip over

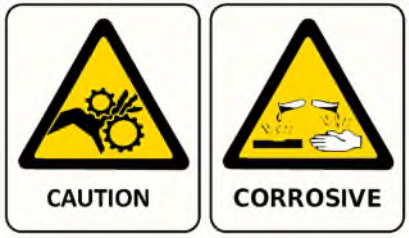

Personal Protective Equipment (PPE)

- MVP recommends the use of personal safety equipment with all products in our catalog.
- Wear safety goggles, hearing protection, a respirator, and chemical resistant gloves.
- Wear long sleeve shirts or jackets and pants to minimize skin exposure.
- PPE should be worn by operators and service technicians to reduce the risk of injury.



For Additional information, contact the Occupational Safety and Health Administration (OSHA). <https://www.osha.gov/about.html>

Symbol Definitions



Indicates the risk of contact with chemicals that are hazardous, which may lead to injury or death.



Indicates the risk of contact with voltage / amperage that may lead to serious injury or death



Indicates that the materials being used are susceptible to combustion



Indicates the risk of contact with moving components that may lead to serious injury or death.



Indicates that the system or component should be grounded before proceeding with use or repair.



Indicates the use of lit cigarettes or cigars is prohibited, because the materials being used are susceptible to combustion.



Indicates that the materials and/or the process being performed can lead to ignition and explosion.



A recommendation for the use of Personal Protective Equipment (PPE) before using or repairing the product.

Polymer Matrix Materials: Advanced Composites

Potential health hazards associated with the use of advanced composites can be controlled through the implementation of an effective industrial hygiene and safety program.

https://www.osha.gov/dts/osta/otm/otm_iii/otm_iii_1.html#t_iii:1_1

| Resins | | |
|--------------------------------------|--|---|
| Composite Component | Organ System Target (Possible Target) | Known (Possible) Health Effect |
| Epoxy resins | Skin, lungs, eyes | Contact and allergic dermatitis, conjunctivitis |
| Polyurethane resins | Lungs, skin, eyes | Respiratory sensitization, contact dermatitis, conjunctivitis |
| Phenol formaldehyde | Skin, lungs, eyes | As above (potential carcinogen) |
| Bismaleimides (BMI) | Skin, lungs, eyes | As above (potential carcinogen) |
| Polyamides | Skin, lungs, eyes | As above (potential carcinogen) |
| Reinforcing materials | | |
| Composite Component | Organ System Target (Possible Target) | Known (Possible) Health Effect |
| Aramid fibers | Skin (lungs) | Skin and respiratory irritation, contact dermatitis (chronic interstitial lung disease) |
| Carbon/graphite fibers | Skin (lungs) | As noted for aramid fibers |
| Glass fibers (continuous filament) | Skin (lungs) | As noted for aramid fibers |
| Hardeners and curing agents | | |
| Composite Component | Organ System Target (Possible Target) | Known (Possible) Health Effect |
| Diaminodiphenylsulfone | N/A | No known effects with workplace exposure |
| Methylenedianiline | Liver, skin | Hepatotoxicity, suspect human carcinogen |
| Other aromatic amines | | |
| Composite Component | Organ System Target (Possible Target) | Known (Possible) Health Effect |
| Meta-phenylenediamine (MPDA) | Liver, skin (kidney, bladder) | Hepatitis, contact dermatitis (kidney and bladder cancer) |
| Aliphatic and cyclo-aliphatic amines | Eyes, skin | Severe irritation, contact dermatitis |
| Polyaminoamide | Eyes, skin | Irritation (sensitization) |
| Anhydride | Eyes, lungs, skin | Severe eye and skin irritation, respiratory sensitization, contact dermatitis |

Catalyst - Methyl Ethyl Ketone Peroxide (MEKP)

MEKP is among the more hazardous materials found in commercial channels. The safe handling of the “unstable (reactive)” chemicals presents a definite challenge to the plastics industry. The highly reactive property which makes MEKP valuable to the plastics industry in producing the curing reaction of polyester resins also produces the hazards which require great care and caution in its storage, transportation, handling, processing and disposal. MEKP is a single chemical. Various polymeric forms may exist which are more or less hazardous with respect to each other. These differences may arise not only from different molecular structures (all are, nevertheless, called “MEKP”) and from possible trace impurities left from the manufacture of the chemicals, but may also arise by contamination of MEKP with other materials in its storage or use. Even a small amount of contamination with acetone, for instance, may produce an extremely shock-sensitive and explosive compound.



WARNING

Contamination with promoters, materials containing promoters (such as laminate sandings), or with any readily oxidizing material (such as brass or iron) will cause exothermic redox reactions which can be explosive in nature. Heat applied to MEKP or heat buildup from contamination reactions can cause the material to reach its Self-Accelerating Decomposition Temperature (SADT).

Researchers have reported measuring pressure rates-of-rise well over 100,000 psi per second when certain MEKP's reach their SADT. For comparison, the highest-pressure rate-of-rise listed in NFPA Bulletin NO.68, “Explosion Venting”, is 12,000 psi per second for an explosion of 12% acetylene and air. The maximum value listed for a hydrogen explosion is 10,000 psi per second. Some forms of MEKP, if allowed to reach their SADT, will burst even an open topped container. This suggests that it is not possible to design a relief valve to vent this order of magnitude of pressure rate-of-rise. The user should be aware that any closed container, be it a pressure vessel, surge chamber, or pressure accumulator, could explode under certain conditions. There is no engineering substitute for care by the user in handling organic peroxide catalysts. If, at any time, the pressure relieve valve on top of the catalyst tank should vent, the area should be evacuated at once and the fire department called. The venting could be the first indication of a heat, and therefore, pressure build-up that could eventually lead to an explosion. Moreover, if a catalyst tank is sufficiently full when the pressure relief valve vents, some catalyst may spray out, which could cause eye injury. For this reason, and many others, anyone whose job puts them in an area where this vented spray might go, should always wear full eye protection even when laminating operations are not taking place.

Safety in handling MEKP depends to a great extent on employee education, proper safety instructions, and safe use of the chemicals and equipment. Workers should be thoroughly informed of the hazards that may result from improper handling of MEKP, especially regarding contamination, heat, friction and impact. They should be thoroughly instructed regarding the proper action to be taken in the storage, use, and disposal of MEKP and other hazardous materials used in the laminating operation. In addition, users should make every effort to:

- Store MEKP in a cool, dry place in original containers away from direct sunlight and away from other chemicals.
- Keep MEKP away from heat, sparks, and open flames.
- Prevent contamination or MEKP with other materials, including polyester over spray and sandings, polymerization accelerators and promoters, brass, aluminum, and non-stainless steels.

- Never add MEKP to anything that is hot, since explosive decomposition may result.
- Avoid contact with skin, eyes, and clothing. Protective equipment should be worn at all times. During clean-up of spilled MEKP, personal safety equipment, gloves, and eye protection must be worn. Firefighting equipment should be at hand and ready.
- Avoid spillage, which can heat up to the point of self-ignition.
- Repair any leaks discovered in the catalyst system immediately, and clean-up the leaked catalyst at once in accordance with the catalyst manufacturer's instructions.
- Use only original equipment or equivalent parts from Magnum Venus Products in the catalyst system (i.e.: hoses, fitting, etc.) because a dangerous chemical reaction may result between substituted parts and MEKP.
- Catalyst accumulated from the purging of hoses or the measurement of fluid output deliveries should never be returned to the supply tank, such catalyst should be diluted with copious quantities of clean water and disposed of in accordance with the catalyst manufacturer's instructions.

The extent to which the user is successful in accomplishing these ends and any additional recommendations by the catalyst manufacturer determines largely the safety that will be present in his operation.

Clean-Up Solvents and Resin Diluents



WARNING

A hazardous situation may be present in your pressurized fluid system! Hydro carbon solvents can cause an explosion when used with aluminum or galvanized components in a closed (pressurized) fluid system (pump, heaters, filters, valves, spray guns, tanks, etc.). An explosion could cause serious injury, death, and/or substantial property damage. Cleaning agents, coatings, paints, etc. may contain Halogenated Hydrocarbon solvents. Some Magnum Venus Products spray equipment includes aluminum or galvanized components and will be affected by Halogenated Hydrocarbon solvents.

There are three key elements to the Halogenated Hydrocarbon (HHC) solvent hazard.

- | | | |
|----|---|--|
| 1. | The presence of HHC solvents. | 1,1,1 – Trichloroethane and Methylene Chloride are the most common of these solvents. However, other HHC solvents are suspect if used; either as part of paint or adhesives formulation, or for clean-up flushing. |
| 2. | Aluminum or Galvanized Parts. | Most handling equipment contains these elements. In contact with these metals, HHC solvents could generate a corrosive reaction of a catalytic nature. |
| 3. | Equipment capable of withstanding pressure. | When HHC solvent contact aluminum or galvanized parts inside a closed container such as a pump, spray gun, or fluid handling system, the chemical reaction can, over time, result in a build-up of heat and pressure, which can reach explosive proportions. When all three elements are present, the result can be an extremely violent explosion. The reaction can be sustained with very little aluminum or galvanized metal; any amount of aluminum is too much. |

- The reaction is unpredictable. Prior use of an HHC solvent without incident (corrosion or explosion) does NOT mean that such use is safe. These solvents can be dangerous alone (as a

clean-up or flushing agent) or when used as a component or a coating material. There is no known inhibitor that is effective under all circumstances. Mixing HHC solvents with other materials or solvents such as MEKP, alcohol, or toluene may render the inhibitors ineffective.

- The use of reclaimed solvents is particularly hazardous. Reclaimers may not add any inhibitors. The possible presence of water in reclaimed solvents could also feed the reaction.
- Anodized or other oxide coatings cannot be relied upon to prevent the explosive reaction. Such coatings can be worn, cracked, scratched, or too thin to prevent contact. There is no known way to make oxide coatings or to employ aluminum alloys to safely prevent the chemical reaction under all circumstances.
- Several solvent suppliers have recently begun promoting HHC solvents for use in coating systems. The increasing use of HHC solvents is increasing the risk. Because of their exemption from many state implementation plans as Volatile Organic Compounds (VOCs), their low flammability hazard, and their not being classified as toxic or carcinogenic substances, HHC solvents are very desirable in many respects.



WARNING

Do not use Halogenated Hydrocarbon (HHC) solvents in pressurized fluid systems having aluminum or galvanized wetted parts. Magnum Venus Products is aware of NO stabilizers available to prevent HHC solvents from reaction under all conditions with aluminum components in closed fluid systems. HHC solvents are dangerous when used with aluminum components in a closed fluid system.

- Consult your material supplier to determine whether your solvent or coating contains Halogenated Hydrocarbon solvents.
- Magnum Venus Products recommends that you contact your solvent supplier regarding the best non-flammable clean-up solvent with the heat toxicity for your application.
- If, however, you find it necessary to use flammable solvents, they must be kept in approved, electrically grounded containers.
- Bulk solvent should be stored in a well-ventilated, separate building, 50 feet away from your main plant.
- You should only allow enough solvent for one day's use in your laminating area.
- NO SMOKING signs must be posted and observed in all areas of storage or where solvents and other flammable materials are used.
- Adequate ventilation (as covered in OSHA Section 1910.94 and NFPA No.91) is important wherever solvents are stored or used, to minimize, confine and exhaust the solvent vapors.
- Solvents should be handled in accordance with OSHA Section 1910.106 and 1910.107.

Catalyst Diluents

Magnum Venus Products spray-up and gel-coat systems currently produced are designed so that catalyst diluents are not required. Magnum Venus Products therefore recommends that diluents not be used to avoid possible contamination which could lead to an explosion due to the handling and mixing of MEKP and diluents. In addition, it eliminates any problems from the diluent being contaminated through rust particles in drums, poor quality control on the part of the diluents suppliers, or any other reason. If diluents are absolutely required, contact your catalyst supplier and follow his instructions explicitly. Preferably the supplier should premix the catalyst to prevent possible “on the job” contamination while mixing.



WARNING

If diluents are not used, remember that catalyst spillage and gun, hose, and packing leaks are potentially more hazardous since each drop contains a higher concentration of catalyst and will therefore react more quickly with overspray and the leak.

Cured Laminate, Overspray and Laminate Sandings Accumulation

- Remove all accumulations of overspray, Fiberglass Reinforced Plastic (FRP) sandings, etc. from the building as they occur. If this waste is allowed to build up, spillage of catalyst is more likely to start a fire; in addition, the fire would burn hotter and longer.
- Floor coverings, if used, should be non-combustible.
- Spilled or leaked catalyst may cause a fire if it comes in contact with an FRP product, oversprayed chop or resin, FRP sandings or any other material with MEKP.

To prevent spillage and leakage, you should:

- | | |
|--|---|
| 1. Maintain your Magnum Venus Products System. | Check the gun several times daily for catalyst and resin packing or valve leaks. REPAIR ALL LEAKS IMMEDIATELY. |
| 2. Never leave the gun hanging over or lying inside the mold. | A catalyst leak in this situation would certainly damage the part, possibly the mold, and may cause a fire. |
| 3. Inspect resin and catalyst hoses daily for wear or stress at the entry and exits of the boom sections and at the hose and fittings. | Replace if wear or weakness is evident or suspected. |
| 4. Arrange the hoses and fiberglass roving guides so that the fiberglass strands DO NOT rub against any of the hoses at any point. | If allowed to rub, the hose will be cut through, causing a hazardous leakage of material which could increase the danger of fire. Also, the material may spew onto personnel in the area. |

Toxicity of Chemicals

- Magnum Venus Products recommends that you consult OSHA Sections 1910.94, 1910.106, 1910.107 and NFPA No.33, Chapter 14, and NFPA No.91.
- Contact your chemical supplier(s) and determine the toxicity of the various chemicals used as well as the best methods to prevent injury, irritation and danger to personnel.
- Also determine the best methods of first aid treatment for each chemical used in your plant.

Equipment Safety

Magnum Venus Products suggest that personal safety equipment such as EYE GOGGLES, GLOVES, EAR PROTECTION, and RESPIRATORS be worn when servicing or operating this equipment. Ear protection should be worn when operating a fiberglass chopper to protect against hearing loss since noise levels can be as high as 116 dB (decibels). This equipment should only be operated or serviced by technically trained personnel!



CAUTION

Never place fingers, hands, or any body part near or directly in front of the spray gun fluid tip. The force of the liquid as it exits the spray tip can cause serious injury by shooting liquid through the skin. NEVER LOOK DIRECTLY INTO THE GUN SPRAY TIP OR POINT THE GUN AT OR NEAR ANOTHER PERSON.



DANGER

Contaminated catalyst may cause fire or explosion. Before working on the catalyst pump or catalyst accumulator, wash hands and tools thoroughly. Be sure work area is free from dirt, grease, or resin. Clean catalyst system components with clean water daily.



DANGER

Eye, skin, and respiration hazard. The catalyst MEKP may cause blindness, skin irritation, or breathing difficulty. Keep hands away from face. Keep food and drink away from work area.

Treatment of Chemical Injuries



CAUTION

Refer to your catalyst manufacturer's safety information regarding the safe handling and storage of catalyst. Wear appropriate safety equipment as recommended.

Great care should be used in handling the chemicals (resins, catalyst and solvents) used in polyester systems. Such chemicals should be treated as if they hurt your skin and eyes and as if they are poison to your body. For this reason, Magnum Venus Products recommends the use of protective clothing and eye wear in using polyester systems. However, users should be prepared in the event of such an injury.

Precautions include:

1. Know precisely what chemicals you are using and obtain information from your chemical supplier on what to do in the event the chemical gets onto your skin or into the eyes, or if swallowed.
2. Keep this information together and easily available so that it may be used by those administering first aid or treating the injured person.
3. Be sure the information from your chemical supplier includes instructions on how to treat any toxic effects the chemicals have.

**WARNING**

Contact your doctor immediately in the event of an injury. If the product's MSDS includes first aid instructions, administer first aid immediately after contacting a doctor.

Fast treatment of the outer skin and eyes that contact chemicals generally includes immediate and thorough washing of the exposed skin and immediate and continuous flushing of the eyes with lots of clean water for at least 15 minutes or more. These general instructions of first aid treatment may be incorrect for some chemicals; you must know the chemicals and treatment before an accident occurs. Treatment for swallowing a chemical frequently depends upon the nature of the chemical.

Emergency Stop Procedure

In an emergency, follow these steps to stop a UPS System:

1. The ball valve located where the air enters the power head of the resin pump, should be moved to the "OFF" or closed position.

Note **The "open" or "on" position is when the ball valve handle is parallel (in line) with the ball valve body. The "closed" or "off" position is when the ball valve handle is perpendicular (across) the ball valve body.**

2. Turn all system regulators to the "OFF" position (counter-clockwise) position.
3. Verify / secure the catalyst relief line, located on the catalyst relief valve.
4. Verify / secure the resin return line, located on the resin filter.
5. Place a container under the resin pump ball valve to catch ejected resin.
6. Locate the ball valve on the resin pump.
7. Rotate the ball valve 90 degrees to the "On" or open position.

Grounding

Grounding an object means providing an adequate path for the flow of the electrical charge from the object to the ground. An adequate path is one that permits charge to flow from the object fast enough that it will not accumulate to the extent that a spark can be formed. It is not possible to define exactly what will be an adequate path under all conditions since it depends on many variables. In any event, the grounding means should have the lowest possible electrical resistance.

Grounding straps should be installed on all loose conductive objects in the spraying area. This includes material containers and equipment. Magnum Venus Products recommends grounding straps be made of AWG No.18 stranded wire as a minimum and the larger wire be used where possible. NFPA Bulletin No77 states that the electrical resistance of such a leakage path may be as low as 1 meg ohm (10 ohms) but that resistance as high as 10,000 meg ohms will produce an adequate leakage path in some cases.



CAUTION

Whenever flammable or combustible liquids are transferred from one container to another, or from one container to the equipment, both containers or container and equipment shall be effectively bonded and grounded to dissipate static electricity. For further information, see National Fire Protection Association (NFPA) 77, titled “Recommended Practice on Static Electrical”. Refer especially to section 7-7 titled “Spray Application of Flammable and Combustible Materials”.

Introduction

This manual provides information for the operation, maintenance, and simple repair of the MVP Cartridge Filling Station. The following procedures are included:

- Step-by-step assembly and disassembly
- Installation, start-up, and shut-down instructions
- Step-by-step operation instructions



Please read this manual carefully and retain for future reference. Follow the steps in the order given, otherwise you may damage the equipment or injure yourself.

Component Assemblies

MVP’s Cartridge Filling Station consists of multiple components. Each component has its own detailed manual and drawings. For complete repair and maintenance instructions, refer to the appropriate manuals.

- PATRIOT SS CHOP CHECK FLUID SECTION MANUAL
- PATRIOT POWERHEAD MANUAL

Air Requirements

1. The system requires a supply of air (30 cfm) and at least 100 psi (7 bar).
2. The unit requires a ½ inch (12 - 13 mm) inside diameter air hose minimum (use caution when using quick disconnects; they may restrict air flow).
3. Preferably the air will be clean, dry, and oil free.

Unit Overview

Below helps identify the main components and controls the operator needs to know for proper operation for the unit.

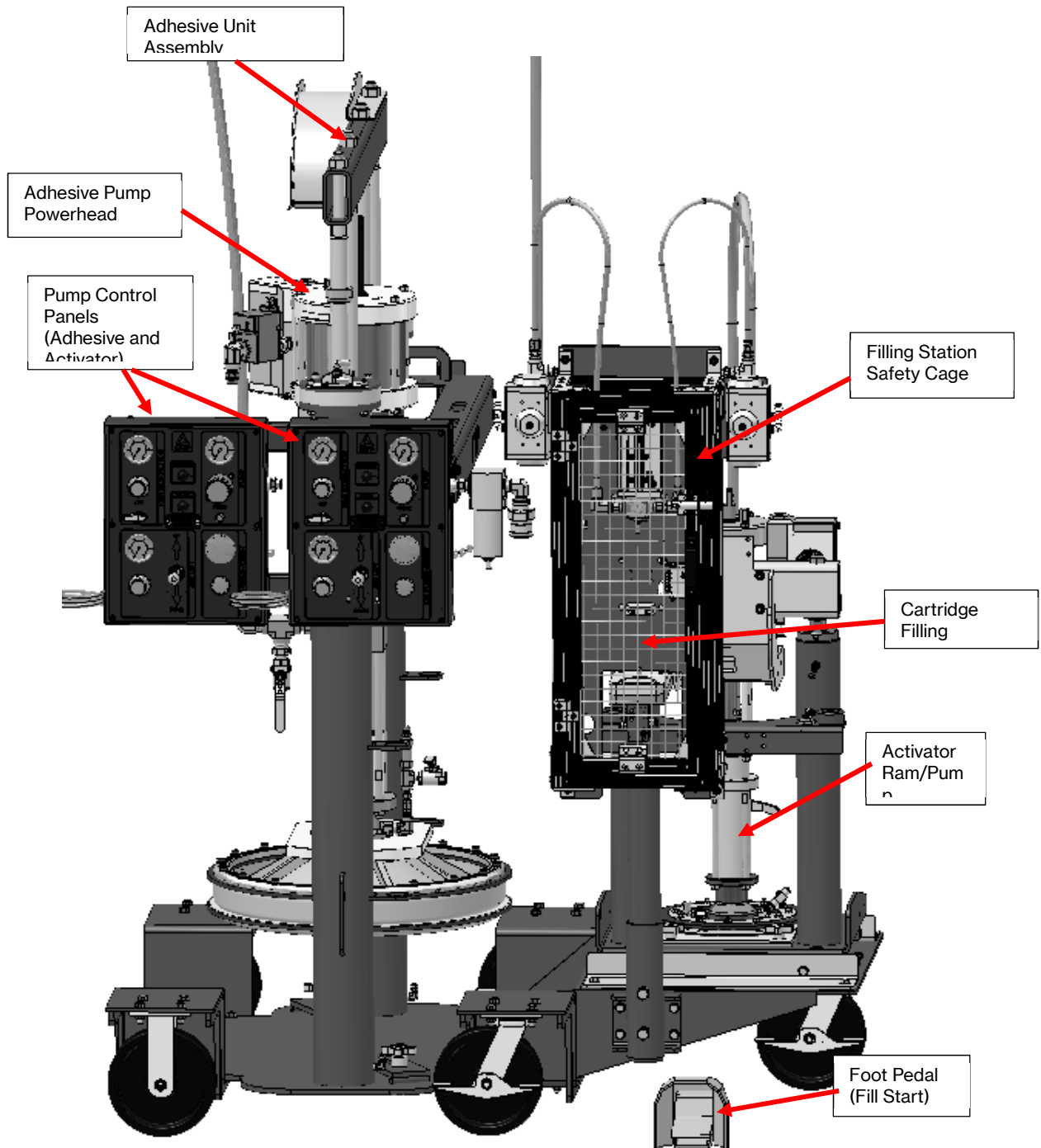

Unit Overview, continued

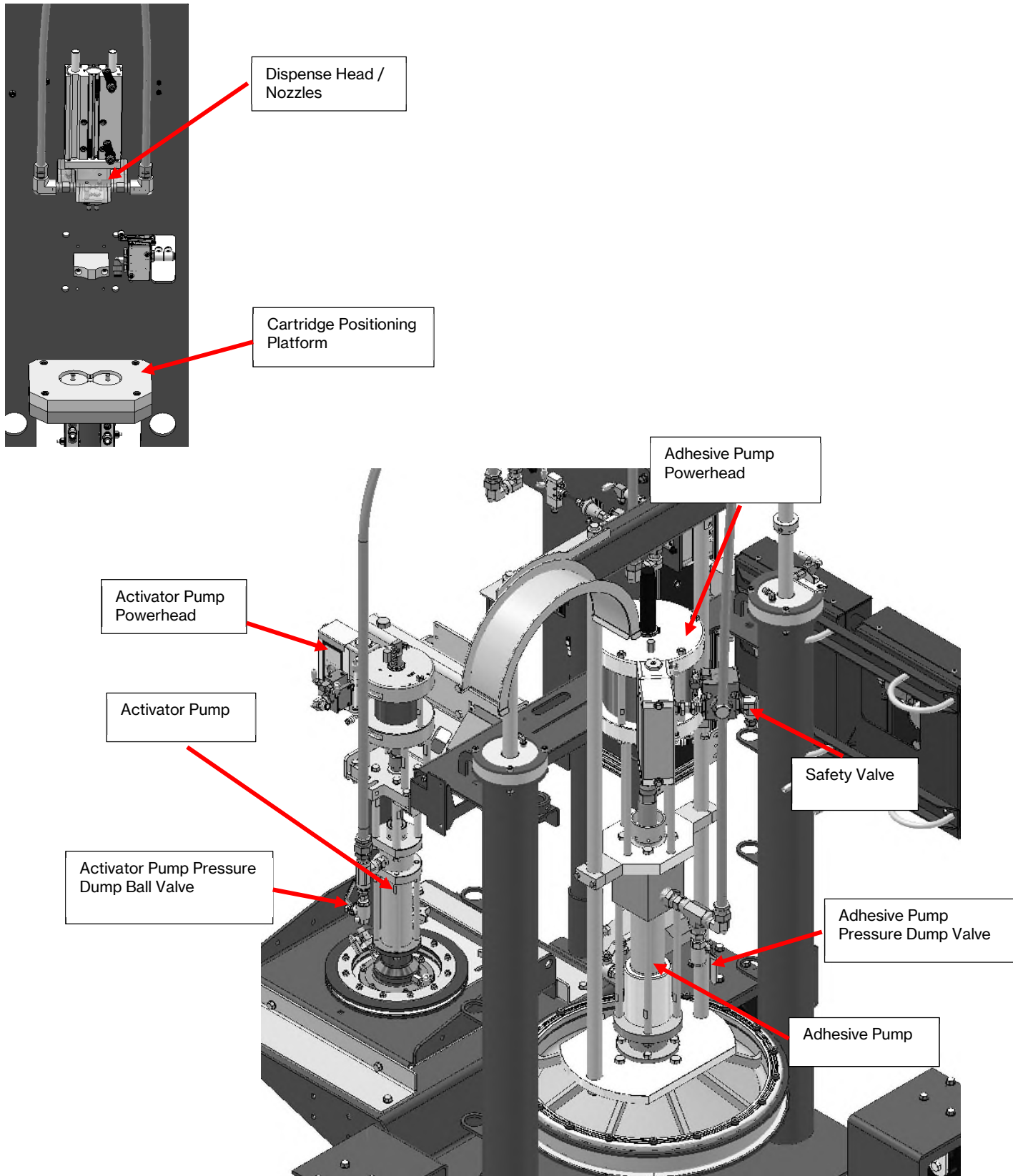

Overview of Controls

Following is a brief description of the main controls and their function. You will need to determine which of the control panels controls the Adhesive Pump and which one controls the Activator Pump. Some controls may be blanked out depending on the unit's configuration.

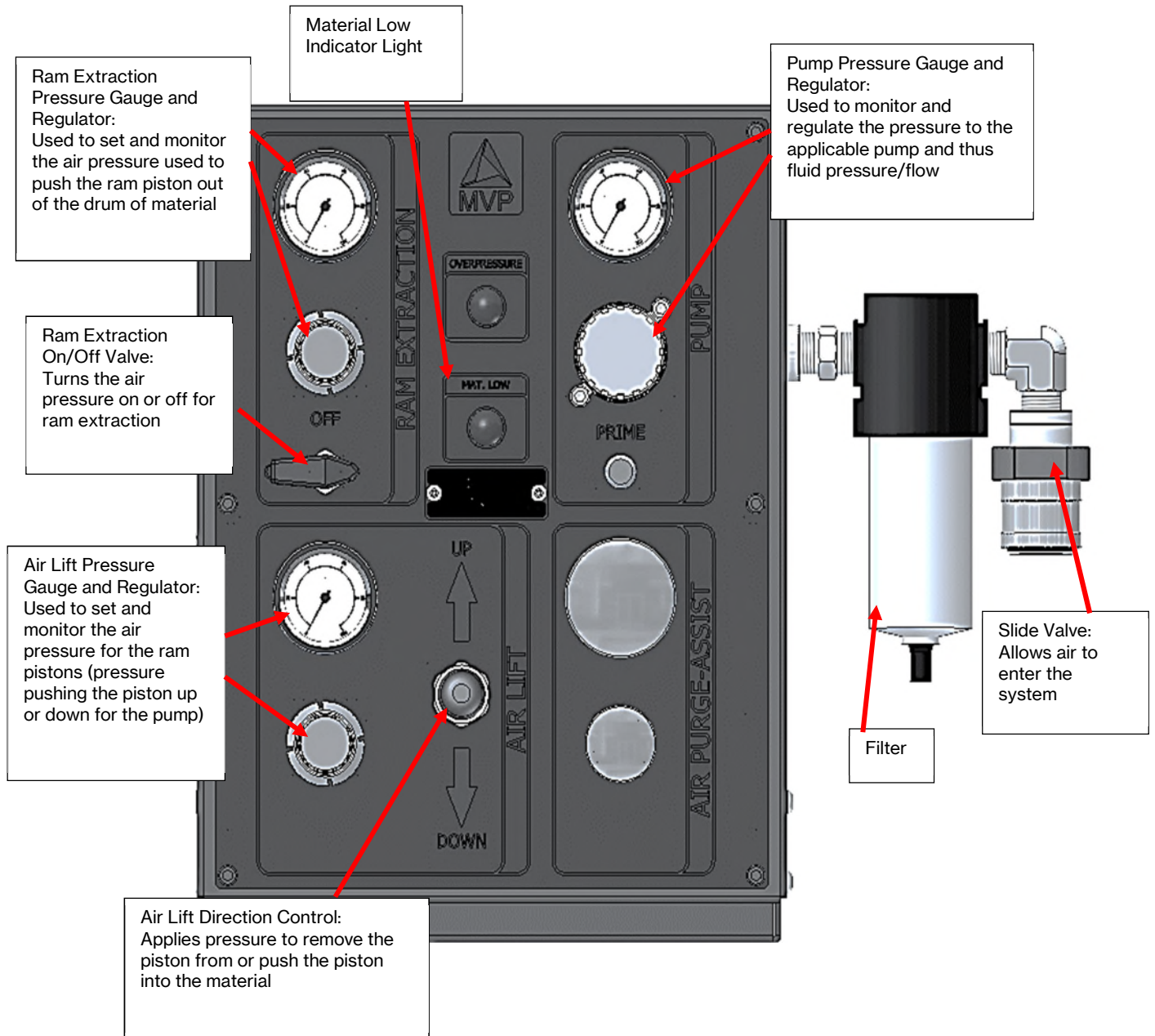

Getting Started



CAUTION

Always wear proper safety equipment (glasses, gloves, respirator, etc.) when working with dispensing equipment and before startup of the unit. Refer to and follow the requirements of the Material Safety Data Sheets (MSDS) supplied by your material manufacturer(s).

Pre-Startup

1. Assemble onto the unit any items that were removed for shipping.
2. Check that all hoses are connected properly and do not show any wear or damage.
3. Check quantities of adhesive and activator and refill or replace as needed.
4. Make sure that neither the adhesive nor activator drum/pail is dented or damaged; this can damage the ram seals.
5. On the ram adhesive unit, check and adjust the ram lower limit by adjusting the bracket to adjust the ram stop position.
 - To set the low-level limit, loosen the bolt holding the shaft collar in place.
 - Slide the shaft collar to the desired position on the post and tighten the bolt back down.
6. Slide the main air supply valve to the **OFF** position.

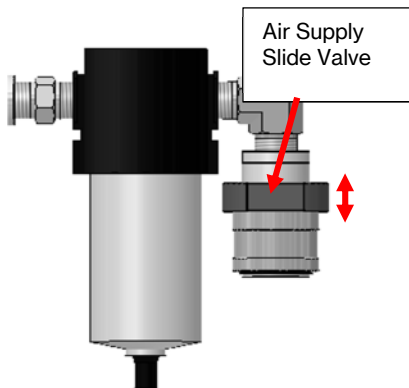
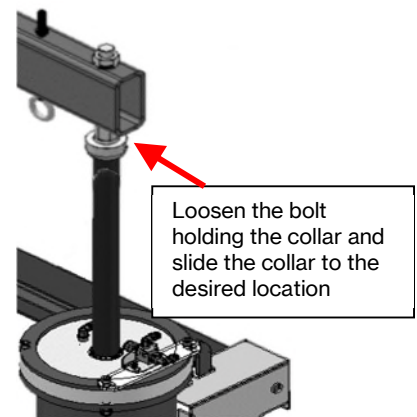

Note *The valve turns off the air supply to the air motor valve, thus stopping the pump.*

7. Connect ½ inch (12mm -13mm) air hose to the inlet port of the slide valve.
8. Press and turn all regulators counterclockwise to full off and close the slide valve on the control panel.
9. Slide the main air supply valve to the ON position

Prime Ram Pumps

Note *Keep the filling station safety cage door closed during priming procedures.*

10. Fill pump solvent cup with ISO oil or equivalent.
11. Push the air lift direction control lever on the adhesive control panel to the **UP** position and release.
12. Slowly increase the air lift pressure regulator to between 5 and 10 psi (0.35 – 0.7 bar).

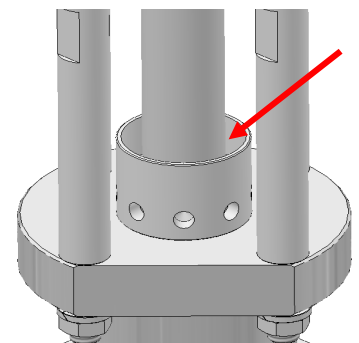

Figure 1. Solvent Cup on Pump

13. As the pump and ram slowly begin to lift, make sure no hoses are catching or kinking.
14. Allow the ram to rise the fully raised position to allow clearance for the drum/container.

Note ***If you are using a 55-gallon drum with a plastic liner, use the ring from the drum top or tape to hold the liner in place and prevent it from being pushed down into the drum.***

15. Slide the container of material onto the unit and center with the barrel piston.
16. Use the plastic piston boot (round piece of plastic with a hole in the center) as a template to make more.
17. Slide a piston boot onto the top of the drum with the hole centered over the opening.
18. Push the air lift direction control lever to the **DOWN** position, then release.
19. As the ram piston begins to move down, make sure that the piston and seals are centered with the drum opening, adjusting as necessary.
20. Position a small container under the ball valve port on top of the ram piston to catch any drips, then open the ball valve to allow air trapped between the piston and material to escape.
21. Allow time for the air to be pushed out of the ball valve.
22. Once the ram piston has started into the container, slowly increase the air lift regulator pressure to between 20 and 40 psi (1.4 to 2.75 bar).
23. Fold the plastic boot back around the top of the ram piston and tape in place if necessary.
24. When the ram piston comes to a complete stop on top of the material (a small amount of material may come out of the ball valve), close the ball valve.

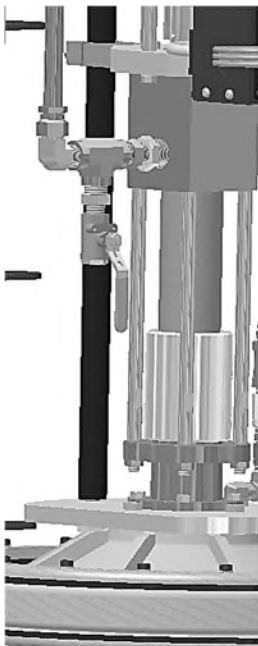
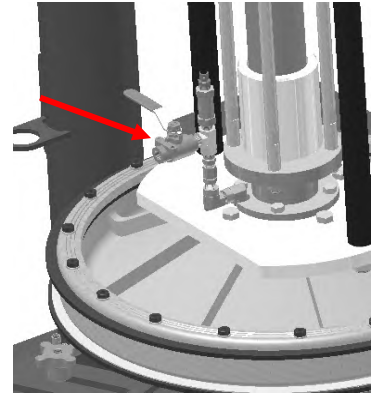

Figure 2. Adhesive Pressure Dump Ball Valve

25. Position a waste container under the pressure dump ball valve (shown in Figure 2), then open the valve.
26. Press and hold the priming button on the appropriate control panel.
27. Slowly increase the pump pressure regulator.
28. Adjust the pump regulator as needed to maintain a slow and uniform movement of the pump.
29. Allow the unit to run until material is being dispensed out of the pressure dump ball valve, then close the valve.
30. Release the priming button to stop the pump.
31. Repeat steps [10](#) through [30](#) for the activator side.

Prime Materials to Dispense Head

32. Open the filling station safety cage door.

33. Remove the two fill level pins from the filling station platform.
34. Place a small waste container onto the filling station platform under the dispense head.
35. Close the filling station safety cage door.
36. Press the foot peddle to start the fill process; the activator and adhesive pumps will begin to move slowly and steadily.
37. Adjust the two pump pressure controls as needed to maintain a slow and steady movement of the pumps.
38. Continue until one or both materials begin to flow from the dispense head.
39. If needed, release the foot peddle and turn one of the pump pressures to zero, then restart the fill process until the other material is also flowing from the dispense head.
40. Once both materials are flowing from the dispense head, continue to dispense until both streams are mostly free of air bubbles.
41. Release the foot peddle to stop the fill process.
42. Open the filling station safety cage door and remove the waste container.
43. Clean the dispense head nozzles as needed.
44. Reinstall the two fill level pins into the filling station platform.

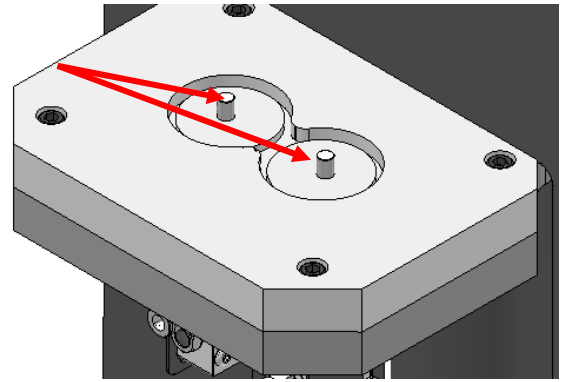

Adjusting the Fill Station

You can adjust the fill station to conform to the requirements of your cartridges. If you need to adjust the settings on your unit, follow the guidelines below.

Dispense Head Height Adjustment

You can adjust the down stop of the dispense head on the switch that the head contacts as it moves down. Loosen the two height adjustment screws to reposition the switch to the desired location.

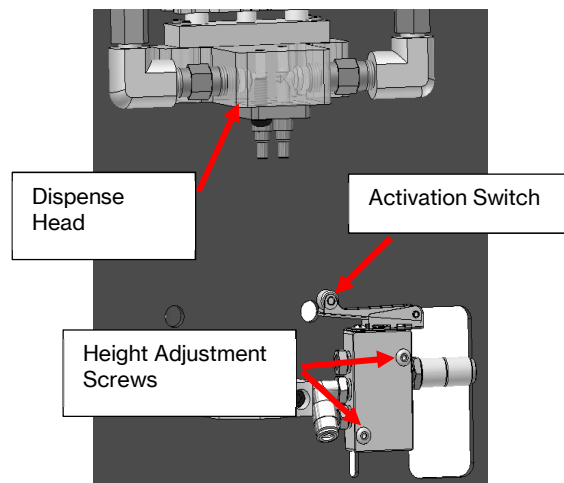

Cartridge Fill Level Adjustment

You can adjust the fill stop to indicate when a cartridge is full by moving the fill level height adjustment screws to change the position of the down stop of the fill level pins on the platform. Each of the two materials has a separate adjustment.

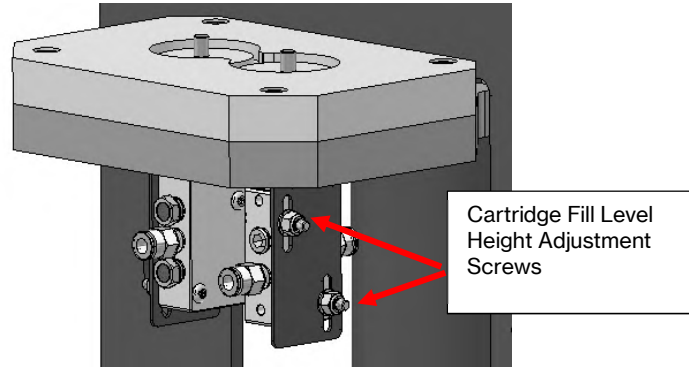

Dispense Head Speed Adjustment

You can adjust the speed of the up and down motion of the dispense head by adjusting the two flow controls on the dispense head cylinder.

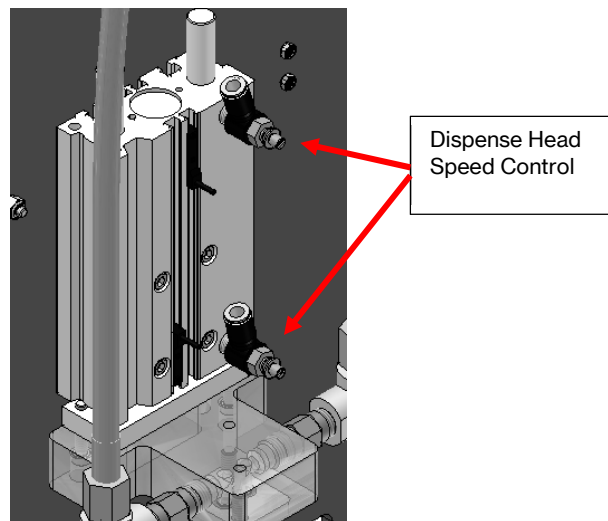

Filling Cartridges

1. Open the filling station safety cage door.
2. Place a new empty cartridge onto the filling station platform, locating the cartridge in the positioning grooves.
3. Close the filling station safety cage door.
4. Press the foot peddle to start the fill process.
5. The dispense head will move down to engage the fill nozzles into the top of the cartridge and the activator and adhesive pumps will begin to move to steadily pump material into the cartridge.

6. Adjust the two pump pressure controls as needed so that the two parts of the cartridge fill at the same time.
7. When both parts of the cartridge are full, the machine will stop.
8. Release the foot peddle to deactivate the pumps and disengage the dispense head from the full cartridge.
9. Remove the full cartridge and replace with a new empty cartridge to continue filling.

Changing an Empty Drum/Pail

Replace Adhesive Drum

1. Position the drum catches on the base by sliding over the lower drum ring and tightening.
2. On the adhesive material control panel, push the air lift direction control lever to **UP** and release.
3. Turn the air lift pressure regulator to zero (0).
4. Turn the ram extraction valve to the **On** position.
5. Slowly turn up the ram extraction regulator to about 20 psi (1.4 bar) until the pump and ram move up and out of the drum slowly and evenly.
6. Make sure the hoses are not catching or kinking as they go up.
7. When the lower seal on the ram is near the top of the drum, air will begin to leak around the seal and the pump and ram will stop moving out of the drum.
8. Remove the tape holding the plastic boot to the ram and allow it to stay with the drum or fall into the empty drum.
9. Turn the ram extraction valve to the **Off** position to stop the air leak.
10. Slowly increase the air lift pressure regulator to between 5 and 10 psi (0.35 – 0.7 bar).
11. As the pump and ram begin to lift, again make sure hoses are not catching or kinking.
12. Allow the pump and ram to rise to the fully raised position, then remove the empty drum and dispose of the plastic boot.
13. Inspect the ram seals.
14. Clean any buildup of material from the ram seals and follower plate.
15. Follow the steps in the Prime Ram Pumps section to load a new drum and prime adhesive again.

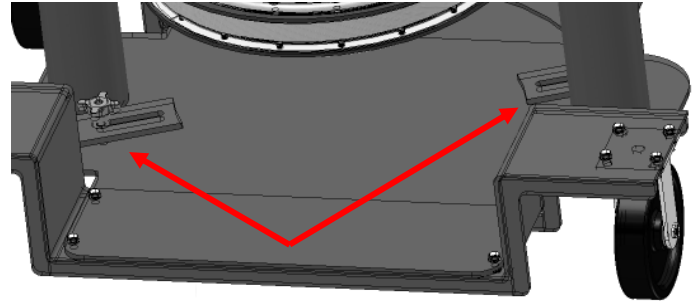

Replace Activator Pail

16. On the activator control panel, push the air lift direction control to the **UP** position and release.
17. Turn the air lift pressure regulator to zero (0).

18. Turn the ram extraction valve to the **On** position.
19. Slowly turn up the ram extraction regulator to about 20 psi (1.4 bar) until the pump and follower plate move up and out of the pail slowly and evenly.
20. Make sure the hoses are not catching or kinking as they go up.
21. When the lower seal on the ram is near the top of the drum, air will begin to leak around the seal and the pump and ram will stop moving out of the drum.
22. Remove the tape holding the plastic boot to the ram and allow it to stay with the pail or fall into the empty pail.
23. Turn the ram extraction valve to the **Off** position to stop the air leak.
24. Slowly increase the air lift pressure regulator to between 5 and 10 psi (0.35 – 0.7 bar).
25. As the pump and ram begin to lift, again make sure hoses are not catching or kinking.
26. Allow the pump and ram to rise to the fully raised position, then remove the empty pail and dispose of the plastic boot.
27. Install a new pail of activator and follow the steps in the Prime Ram Pumps section to prime the unit again.

Performing Daily Procedures

Starting Up

1. Check all materials and replace as needed.
2. Slide the main air valve open to pressurize the system.
3. Check the air filter and bleed off any water accumulated.
4. Check the system for leaks or damage; repair or replace items as needed.
5. Check that air lift pressure is set correctly and adjust if needed.
6. Check both pump air pressure settings are correct; if needed press and hold the priming button while adjusting the pump pressure.
7. Open the filling station safety cage door and position a cartridge in the grooves to begin the filling process.
8. The system is ready for use.

Shutting Down

9. Thoroughly clean the filling station platform and surrounding area.
10. Wipe and clean the dispense head nozzles and check the area for damage.
11. Slide the main air valve to the closed position.